

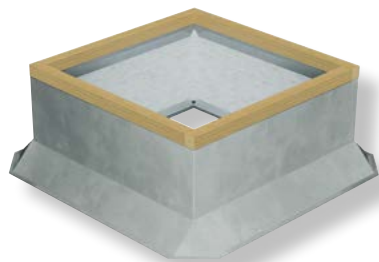

INDUSTRIAL PROCESS AND  
COMMERCIAL VENTILATION SYSTEMS

# PREFABRICATED ROOF CURBS



Canted



Self-Flashing Vented  
(Restaurant)



Self-Flashing



Fiberglass Roof Curb

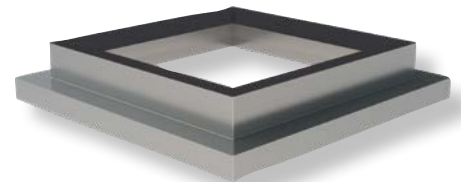

Curb Adapter

# CANTED ROOF CURB

## Series RCPF

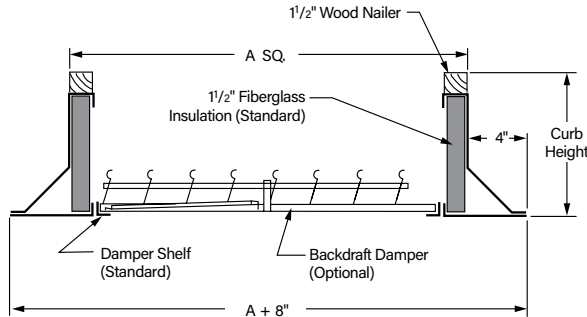

### NOTES:

1. Curbs are sized 1/2" less than fan base to allow 3/4" each side for flashing material and clearance.
2. Inside of curb is 3" less than Dimension "A".
3. For aluminum curb substitute RCPFAl in place of RCPFGL.
4. When using a motor operated damper in the curb, a 12"-high (minimum) curb is required.

### Features

- Constructed of 18-gauge galvanized steel with continuously-welded seams
- Large 3" built-in 45° cant to accommodate roofing material to top of curb. Cant is beveled at corners for better support of roofing material
- Wood nailer (1/2") secured to top ledge
- Lined with 1/2" fiberglass fire-resistant, sound-absorbing insulation
- Damper shelf

### Options

- Aluminum (16-gauge) construction
- Burglar security bars
- Metal liner (galvanized or aluminum)
- Special heights up to 24"

MODEL	FAN		ROOF CURB DIM. A (SQ)	PART NUMBER		
	SIZE	BASE I.D.		8" HIGH CURB	12" HIGH CURB	18" HIGH CURB
BCRFS	090	24 x 24	22.5 x 22.5	RC22508PFGI	RC22512PFGI	RC22518PFGI
	100	30 x 30	28.5 x 28.5	RC28508PFGI	RC28512PFGI	RC28518PFGI
	120, 150	34 x 34	32.5 x 32.5	RC32508PFGI	RC32512PFGI	RC32518PFGI
	180	40 x 40	38.5 x 38.5	RC38508PFGI	RC38512PFGI	RC38518PFGI
	200	46 x 46	44.5 x 44.5	RC44508PFGI	RC44512PFGI	RC44518PFGI
	220	54 x 54	52.5 x 52.5	RC52508SFGI	RC52512SFGI	RC52518SFGI
BCRD	70, 75, 85	17 x 17	15.5 x 15.5	RC15508PFGI	RC15512PFGI	RC15518PFGI
	100, 120	20 x 20	18.5 x 18.5	RC18508PFGI	RC18512PFGI	RC18518PFGI
	140	24 x 24	22.5 x 22.5	RC22508PFGI	RC22512PFGI	RC22518PFGI
	160	26 x 26	24.5 x 24.5	RC24508PFGI	RC24512PFGI	RC24518PFGI
	180, 210	30 x 30	28.5 x 28.5	RC28508PFGI	RC28512PFGI	RC28518PFGI
	240	34 x 34	32.5 x 32.5	RC32508PFGI	RC32512PFGI	RC32518PFGI
	300	40 x 40	38.5 x 38.5	RC38508PFGI	RC38512PFGI	RC38518PFGI
	360	46 x 46	44.5 x 44.5	RC44508PFGI	RC44512PFGI	RC44518PFGI
	420	52 x 52	50.5 x 50.5	RC50508PFGI	RC50512PFGI	RC50518PFGI
	480	58 x 58	56.5 x 56.5	RC56508PFGI	RC56512PFGI	RC56518PFGI
BCRU	180	30 x 30	28.5 x 28.5	RC28508PFGI	RC28512PFGI	RC28518PFGI
	210, 240	34 x 34	32.5 x 32.5	RC32508PFGI	RC32512PFGI	RC32518PFGI
	300	40 x 40	38.5 x 38.5	RC38508PFGI	RC38512PFGI	RC38518PFGI
	360	46 x 46	44.5 x 44.5	RC44508PFGI	RC44512PFGI	RC44518PFGI
	420	52 x 52	50.5 x 50.5	RC50508PFGI	RC50512PFGI	RC50518PFGI
	480	58 x 58	56.5 x 56.5	RC56508PFGI	RC56512PFGI	RC56518PFGI
DCRD	120	20 x 20	18.5 x 18.5	RC18508PFGI	RC18512PFGI	RC18518PFGI
	130, 140, 150, 160	24 x 24	22.5 x 22.5	RC22508PFGI	RC22512PFGI	RC22518PFGI
	170, 180	30 x 30	28.5 x 28.5	RC28508PFGI	RC28512PFGI	RC28518PFGI
DCRU	180	30 x 30	28.5 x 28.5	RC28508PFGI	RC28512PFGI	RC28518PFGI
GRV	90	16.5 x 16.5	15 x 15	RC15008PFGI	RC15012PFGI	RC15018PFGI
	120, 160	24 x 24	22.5 x 22.5	RC22508PFGI	RC22512PFGI	RC22518PFGI
	180, 210	29.5 x 29.5	28 x 28	RC28008PFGI	RC28012PFGI	RC28018PFGI
	240, 270	35.5 x 35.5	34 x 34	RC34008PFGI	RC34012PFGI	RC34018PFGI
	300, 320, 360	42.5 x 42.5	41 x 41	RC41008PFGI	RC41012PFGI	RC41018PFGI
	420	52 x 52	50.5 x 50.5	RC50508PFGI	RC50512PFGI	RC50518PFGI
	480	58 x 58	56.5 x 56.5	RC56508PFGI	RC56512PFGI	RC56518PFGI
VC	077, 083, 085, 089, 098, 112, 120	17 x 17	15.5 x 15.5	RC15508PFGI	RC15512PFGI	RC15518PFGI
	085	17 x 17	15.5 x 15.5	RC15508PFGI	RC15512PFGI	RC15518PFGI
VCU	089, 098, 110, 112	20 x 20	18.5 x 18.5	RC18508PFGI	RC18512PFGI	RC18518PFGI
	122, 124, 135, 140, 150, 157, 165	24 x 24	22.5 x 22.5	RC22508PFGI	RC22512PFGI	RC22518PFGI
	122, 124, 135, 140, 150, 157, 165	24 x 24	22.5 x 22.5	RC22508PFGI	RC22512PFGI	RC22518PFGI
VCUB	122, 124, 135, 140, 150, 157, 165	24 x 24	22.5 x 22.5	RC22508PFGI	RC22512PFGI	RC22518PFGI

DIMENSIONS ARE NOT TO BE USED FOR CONSTRUCTION.

# SELF-FLASHING ROOF CURB

## Series RCSF

### Features

- Constructed of 18-gauge galvanized steel with continuously-welded seams
- Wide base plate (flashing) to ensure watertight bond to roof
- Top ledge covered with  $\frac{3}{16}$ " polystyrene gasket for weather seal and to reduce metal-to-metal conducted noise
- Lined with  $\frac{1}{2}$ " fiberglass fire-resistant, sound-absorbing insulation
- Damper shelf

### Options

- Aluminum (16-gauge) construction
- Burglar security bars
- Metal liner (galvanized or aluminum)
- Special heights up to 24"
- Wood nailer ( $\frac{1}{2}$ " ) secured to top ledge in lieu of polystyrene gasket
- Single- or double-pitched curbs for sloping roofs

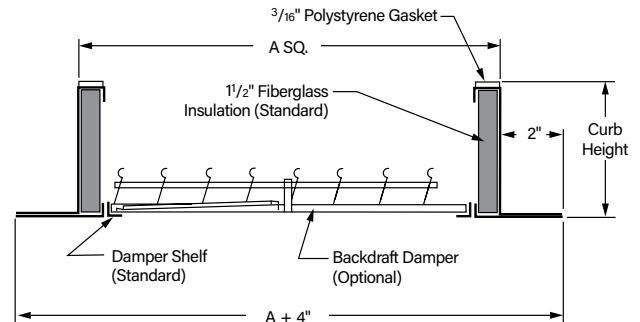

#### NOTES:

1. Curbs are sized  $\frac{1}{2}$ " less than fan base to allow  $\frac{1}{4}$ " each side for clearance.
2. Inside of curb is 3" less than Dimension "A".
3. For aluminum curb substitute RCSFAl in place of RCSFGI.
4. When using a motor operated damper in the curb, a 12"-high (minimum) curb is required.

MODEL	FAN		ROOF CURB DIM. A (SQ)	PART NUMBER		
	SIZE	BASE I.D.		8" HIGH CURB	12" HIGH CURB	18" HIGH CURB
BCRFS	090	24 x 24	23 x 23	RC23008SFGI	RC23012SFGI	RC23018SFGI
	100	30 x 30	29 x 29	RC29008SFGI	RC29012SFGI	RC29018SFGI
	120, 150	34 x 34	33 x 33	RC33008SFGI	RC33012SFGI	RC33018SFGI
	180	40 x 40	39 x 39	RC39008SFGI	RC39012SFGI	RC39018SFGI
	200	46 x 46	45 x 45	RC45008SFGI	RC45012SFGI	RC45018SFGI
	220	54 x 54	53 x 53	RC53008SFGI	RC53012SFGI	RC53018SFGI
BCRD	70, 75, 85	17 x 17	16.5 x 16.5	RC16508SFGI	RC16512SFGI	RC16518SFGI
	100, 120	20 x 20	19.5 x 19.5	RC19508SFGI	RC19512SFGI	RC19518SFGI
	140	24 x 24	23.5 x 23.5	RC23508SFGI	RC23512SFGI	RC23518SFGI
	160	26 x 26	25.5 x 25.5	RC25508SFGI	RC25512SFGI	RC25518SFGI
	180, 210	30 x 30	29.5 x 29.5	RC29508SFGI	RC29512SFGI	RC29518SFGI
	240	34 x 34	33.5 x 33.5	RC33508SFGI	RC33512SFGI	RC33518SFGI
	300	40 x 40	39.5 x 39.5	RC39508SFGI	RC39512SFGI	RC39518SFGI
	360	46 x 46	45.5 x 45.5	RC45508SFGI	RC45512SFGI	RC45518SFGI
	420	52 x 52	51.5 x 51.5	RC51508SFGI	RC51512SFGI	RC51518SFGI
480	58 x 58	57.5 x 57.5	RC57508SFGI	RC57512SFGI	RC57518SFGI	
BCRU	180	30 x 30	29.5 x 29.5	RC29508SFGI	RC29512SFGI	RC29518SFGI
	210, 240	34 x 34	33.5 x 33.5	RC33508SFGI	RC33512SFGI	RC33518SFGI
	300	40 x 40	39.5 x 39.5	RC39508SFGI	RC39512SFGI	RC39518SFGI
	360	46 x 46	45.5 x 45.5	RC45508SFGI	RC45512SFGI	RC45518SFGI
	420	52 x 52	51.5 x 51.5	RC51508SFGI	RC51512SFGI	RC51518SFGI
	480	58 x 58	57.5 x 57.5	RC57508SFGI	RC57512SFGI	RC57518SFGI
DCRD	120	20 x 20	19.5 x 19.5	RC19508SFGI	RC19512SFGI	RC19518SFGI
	130, 140, 150, 160	24 x 24	23.5 x 23.5	RC23508SFGI	RC23512SFGI	RC23518SFGI
	170, 180	30 x 30	29.5 x 29.5	RC29508SFGI	RC29512SFGI	RC29518SFGI
DCRU	180	30 x 30	29.5 x 29.5	RC29508SFGI	RC29512SFGI	RC29518SFGI
GRV	90	16.5 x 16.5	16 x 16	RC16008SFGI	RC16012SFGI	RC16018SFGI
	120, 160	24 x 24	23.5 x 23.5	RC23508SFGI	RC23512SFGI	RC23518SFGI
	180, 210	29.5 x 29.5	29 x 29	RC29008SFGI	RC29012SFGI	RC29018SFGI
	240, 270	35.5 x 35.5	35 x 35	RC35008SFGI	RC35012SFGI	RC35018SFGI
	300, 320, 360	42.5 x 42.5	42 x 42	RC42008SFGI	RC42012SFGI	RC42018SFGI
	420	52 x 52	51.5 x 51.5	RC51508SFGI	RC51512SFGI	RC51518SFGI
	480	58 x 58	57.5 x 57.5	RC57508SFGI	RC57512SFGI	RC57518SFGI
VC	077, 083, 085, 089, 098, 112, 120	17 x 17	16.5 x 16.5	RC16508SFGI	RC16512SFGI	RC16518SFGI
VCU	085	17 x 17	16.5 x 16.5	RC16508SFGI	RC16512SFGI	RC16518SFGI
	089, 098, 110, 112	20 x 20	19.5 x 19.5	RC19508SFGI	RC19512SFGI	RC19518SFGI
	122, 124, 135, 140, 150, 157, 165	24 x 24	23.5 x 23.5	RC23508SFGI	RC23512SFGI	RC23518SFGI
	VCUB	122, 124, 135, 140, 150, 157, 165	24 x 24	23.5 x 23.5	RC23508SFGI	RC23512SFGI

DIMENSIONS ARE NOT TO BE USED FOR CONSTRUCTION.

# SELF-FLASHING VENTED ROOF CURB

## Series RCSFV

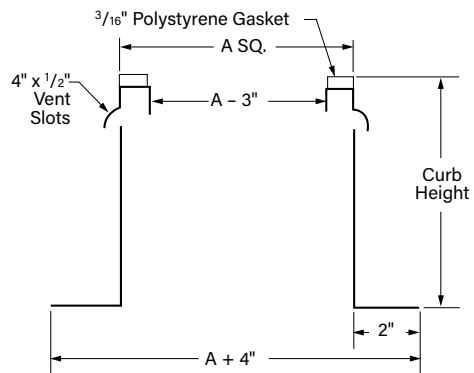

### NOTES:

1. Curbs are sized 1/2" less than fan base to allow 3/4" clearance on each side for curb hinge (if required).

### Features

- Completely assembled unit, easier to install and less expensive than a field constructed curb
- Constructed of 18-gauge galvanized steel with continuously-welded seams with wide base flashing for weathertight seal to roof
- Meets NFPA-96 code requirements
- Top ledge covered with 3/16" polystyrene gasket
- Furnished with ventilation slots

*For Use on Roof Mounted Restaurant Exhaust Fans*

MODEL	FAN		ROOF CURB DIM. A (SQ)	PART NUMBER	
	SIZE	BASE I.D.		12" HIGH CURB	18" HIGH CURB
BCRUR	180	30 x 30	28.5 x 28.5	RC28512SFVG	RC28518SFVG
	210	34 x 34	32.5 x 32.5	RC32512SFVG	RC32518SFVG
	240				
	300	40 x 40	38.5 x 38.5	RC38512SFVG	RC38518SFVG
	360	46 x 46	44.5 x 44.5	RC44512SFVG	RC44518SFVG
DCRUR	180	30 x 30	28.5 x 28.5	RC28512SFVG	RC28518SFVG

DIMENSIONS ARE NOT TO BE USED FOR CONSTRUCTION.



# SOUND ATTENUATING ROOF CURB

## Series RCSA

### Features

- Reduces the roof fan noise transmitted into building. Typical performance of sound attenuating curb will result in a 40% reduction of sone value with a 7% loss in CFM
- Designed with streamlined airflow passages using a core of modular type sound-absorbing cells of special fiberglass held in a galvanized steel frame
- Constructed of 18-gauge galvanized steel with continuously-welded seams
- Large 3" built-in 45° cant to accommodate roofing material to top of curb
- Wood nailer (1 1/2") secured to top ledge
- Lined with 1 1/2" fiberglass fire-resistant, sound-absorbing insulation
- Damper box

### Options

- Aluminum (16-gauge) construction
- Also available in self-flashing or raised cant design

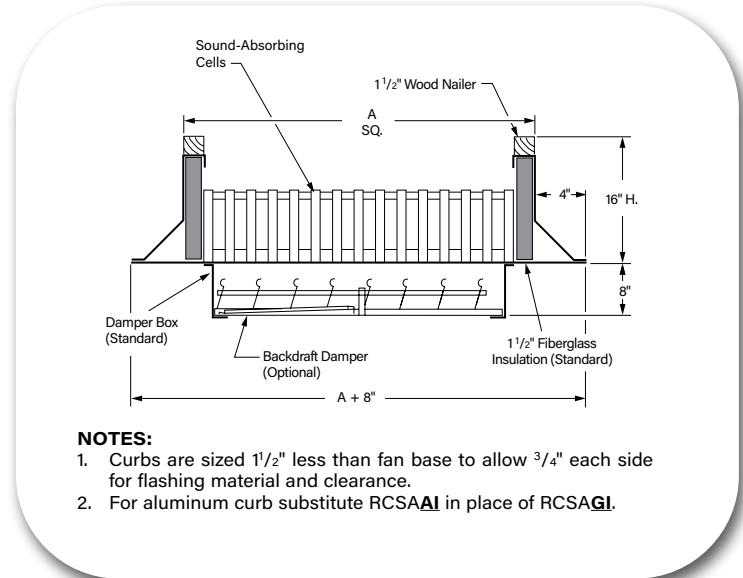

*A special sound-absorbing curb designed for use with power roof ventilators where exceptionally quiet operation is required.*

MODEL	FAN		ROOF CURB DIM. A (SQ)	PART NUMBER
	SIZE	BASE I.D.		
BCRD	70, 75, 85	17 x 17	15.5 x 15.5	RC15516SAGI
	100, 120	20 x 20	18.5 x 18.5	RC18516SAGI
	140	24 x 24	22.5 x 22.5	RC22516SAGI
	160	26 x 26	24.5 x 24.5	RC24516SAGI
	180, 210	30 x 30	28.5 x 28.5	RC28516SAGI
	240	34 x 34	32.5 x 32.5	RC32516SAGI
	300	40 x 40	38.5 x 38.5	RC38516SAGI
	360	46 x 46	44.5 x 44.5	RC44516SAGI
	420	52 x 52	50.5 x 50.5	RC50516SAGI
BCRU	480	58 x 58	56.5 x 56.5	RC56516SAGI
	180	30 x 30	28.5 x 28.5	RC28516SAGI
	210, 240	34 x 34	32.5 x 32.5	RC32516SAGI
	300	40 x 40	38.5 x 38.5	RC38516SAGI
	360	46 x 46	44.5 x 44.5	RC44516SAGI
	420	52 x 52	50.5 x 50.5	RC50516SAGI
DCRD	120	20 x 20	18.5 x 18.5	RC18516SAGI
	130, 140, 150, 160	24 x 24	22.5 x 22.5	RC22516SAGI
	170, 180	30 x 30	28.5 x 28.5	RC28516SAGI
DCRU	180	30 x 30	28.5 x 28.5	RC28516SAGI
VC	077, 083, 085, 089, 098, 112, 120	17 x 17	15.5 x 15.5	RC15516SAGI
	085	17 x 17	15.5 x 15.5	RC15516SAGI
VCU	089, 098, 110, 112	20 x 20	18.5 x 18.5	RC18516SAGI
	122, 124, 135, 140, 150, 157, 165	24 x 24	22.5 x 22.5	RC22516SAGI
	122, 124, 135, 140, 150, 157, 165	24 x 24	22.5 x 22.5	RC22516SAGI

DIMENSIONS ARE NOT TO BE USED FOR CONSTRUCTION.

### Sound Curb Pressure Loss

VELOCITY FPM*	ΔP IN. W.G.
200	.01
400	.02
600	.04
800	.07
1000	.11
1200	.16
1500	.25
2000	.44

\*Velocity through curb inlet.





# ROOF CURB ADAPTER

## Series RCCA

### Features

- Constructed of heavy-gauge galvanized steel with continuously-welded seams
- Top ledge covered with  $\frac{3}{16}$ " polystyrene gasket to reduce metal-to-metal conducted noise and act as a weather seal

#### Style A

(For use with  
oversize, existing curb)

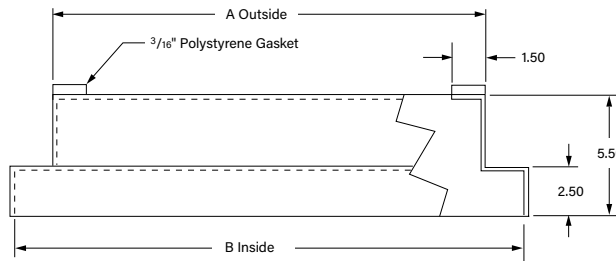

#### Recommended Sizing:

Dimension A = Fan Base (Cap)  
Minus  $\frac{1}{2}$ "

Dimension B = Roof Curb Outside  
Dimension Plus  $\frac{1}{2}$ "

#### Style B

(For use with  
smaller, existing curb)

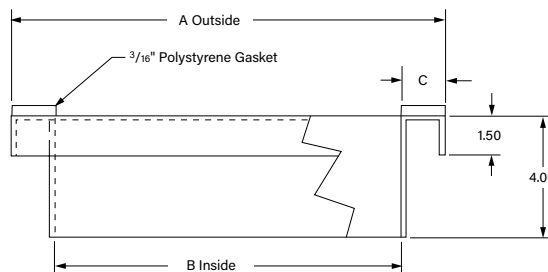

#### Recommended Sizing:

Dimension A = Fan Base (Cap)  
Minus  $\frac{1}{2}$ "

Dimension B = Roof Curb Outside  
Dimension Plus  $\frac{1}{2}$ "

Dimension C =  $(A - B) \div 2$

**Note:** Use of a large fan on a smaller, existing curb may cause an inlet obstruction and result in reduced fan performance.

DIMENSIONS ARE NOT TO BE USED FOR CONSTRUCTION.

# ROOF CURB EXTENSION

## Series RCCE

### Features

- Constructed of 18-gauge galvanized steel with continuously-welded seams for water tightness and extra strength
- $\frac{3}{16}$ " polystyrene gasket on top ledge to reduce metal-to-metal conducted noise and act as a weather seal
- Lined with  $\frac{1}{2}$ " fiberglass fire resistant, sound absorbing insulation
- Built-in back draft damper shelf and removable access panel

### Options

- Heights up to 24" (13" is standard)
- Vent slots (no insulation or damper shelf)

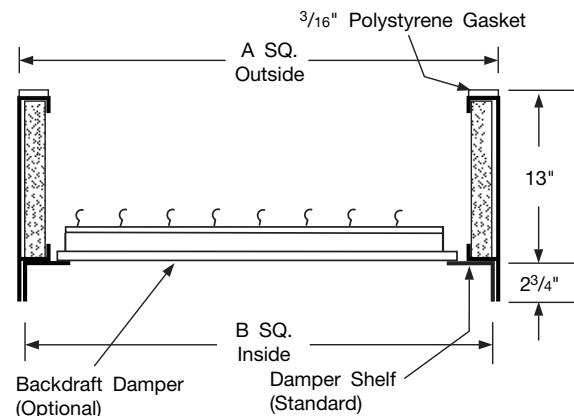

#### Recommended Sizing:

Dimension A = Fan Base Minus  $\frac{1}{2}$ "

Dimension B = A Minus  $\frac{1}{4}$ "

## Series EF (w/insulation)

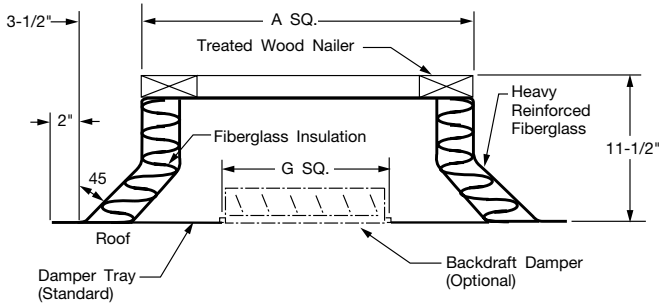

**E12F** — A 12" high, beige color, molded fiberglass, reinforced polyester resin, double shell, prefabricated roof curb with a 3<sup>1</sup>/<sub>2</sub>" cant, corner gussets, 2" thick fiberglass insulation and incorporating a treated 1<sup>1</sup>/<sub>2</sub>" x 3<sup>1</sup>/<sub>2</sub>" treated wood nailer and damper tray.

## Series E

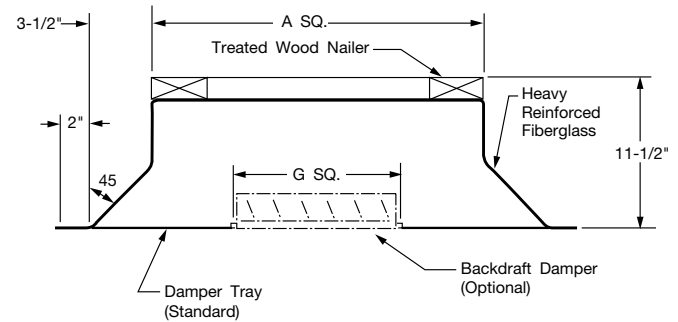

**E12** — A 12" high, beige color, molded fiberglass, reinforced polyester resin, single shell, prefabricated roof curb with a 3<sup>1</sup>/<sub>2</sub>" cant, corner gussets and incorporating a treated 1<sup>1</sup>/<sub>2</sub>" x 3<sup>1</sup>/<sub>2</sub>" treated wood nailer and damper tray.

MODEL	FAN / HOOD		ROOF CURB DIM. A (SQ)	12" HIGH CURB WITH INSULATION		12" HIGH CURB NON-INSULATED		G (SQ)	DAMPER SIZE WHEN REQ'D
	SIZE	BASE I.D.		PART NUMBER	APPROX. SHIP WT. (LB)	PART NUMBER	APPROX. SHIP WT. (LB)		
WA	7	17 x 17	16 x 16	15025102	31	15025002	26	6.63	6 x 6
	10, 12	21 x 21	20 x 20	15025104	38	15025004	31	10.63	10 x 10
	14	24.8 x 24.8	24 x 24	15025105	46	15025005	38	14.63	14 x 14
	18	29 x 29	28 x 28	15025107	53	15025007	44	18.63	18 x 18
WAB	14	24.8 x 24.8	24 x 24	15025105	46	15025005	38	14.63	14 x 14
	18	29 x 29	28 x 28	15025107	53	15025007	44	18.63	18 x 18
	24	37.5 x 37.5	36 x 36	15025109	68	15025009	56	24.63	24 x 24
	30	45.5 x 45.5	44 x 44	15025112	82	15025012	67	30.63	30 x 30
	36, 40	53 x 53	52 x 52	15025115	99	15025015	80	36.63	36 x 36

**NOTE:** Damper to have 1<sup>5</sup>/<sub>8</sub>" flange.

DIMENSIONS ARE NOT TO BE USED FOR CONSTRUCTION.

# INDUSTRIAL PROCESS AND COMMERCIAL VENTILATION SYSTEMS

CENTRIFUGAL FANS | UTILITY SETS | PLENUM & PLUG FANS | INLINE CENTRIFUGAL FANS

MIXED FLOW FANS | TUBEAXIAL & VANEAXIAL FANS | WALL MOUNTED FANS | ROOF VENTILATORS

CENTRIFUGAL ROOF & WALL EXHAUSTERS | CEILING VENTILATORS | GRAVITY VENTILATORS | DUCT BLOWERS

RADIAL BLADED FANS | RADIAL TIP FANS | HIGH EFFICIENCY INDUSTRIAL FANS | PRESSURE BLOWERS

LABORATORY EXHAUST FANS | FILTERED SUPPLY FANS | MANCOOLERS | FIBERGLASS FANS | CUSTOM FANS



**TWIN CITY FAN & BLOWER**  
**[WWW.TCF.COM](http://WWW.TCF.COM)**

5959 TRENTON LANE N. | MINNEAPOLIS, MN 55442 | PHONE: 763-551-7600 | FAX: 763-551-7601

©2001-2023 Twin City Fan Companies, Ltd., Minneapolis, MN. All rights reserved. Catalog illustrations cover the general appearance of Twin City Fan & Blower products at the time of publication and we reserve the right to make changes in design and construction at any time without notice.