

Throughout this manual, there are a number of HAZARD WARNINGS that must be read and adhered to in order to prevent possible personal injury and/or damage to equipment. The signal word "CAUTION" is used to indicate the severity of a hazard and is preceded by the safety alert symbol.

⚠ CAUTION

Used when minor or moderate injury or product / equipment damage MAY result from misuse or failure to follow specific instructions.

NOTICE

Indicates information considered important, but not hazard-related.

It is the responsibility of all personnel involved in installation, operation and maintenance to fully understand the **⚠** Caution procedures by which hazards are to be avoided.

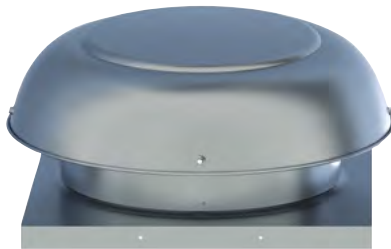

MODEL GRV

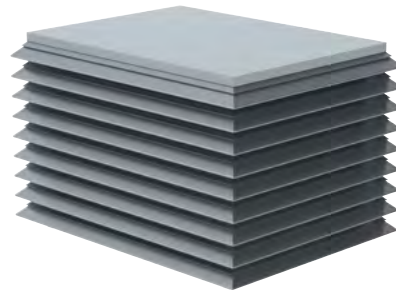

MODELS TEL & TIL

MODELS GRV, TEL, TIL

Twin City Fan & Blower Catalog 4720 provides additional information on this equipment. This catalog can be found at www.tcf.com or by contacting your local Twin City Fan & Blower sales representative.

NOMENCLATURE

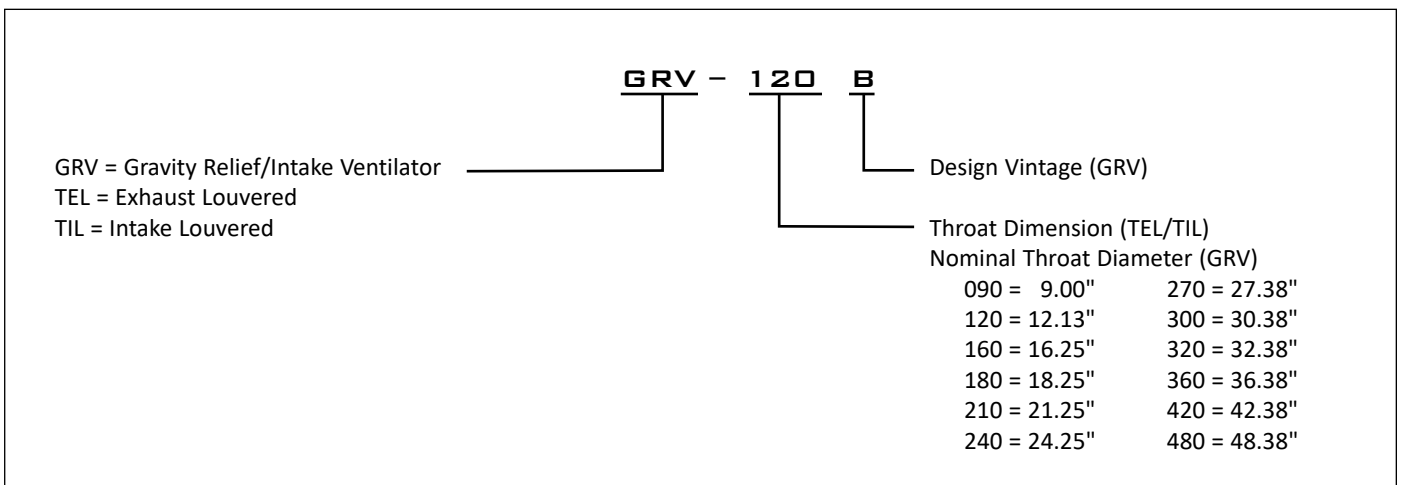

RECEIVING, INSPECTION & UNPACKING

When the equipment is received all items should be carefully checked against the bill of lading to be sure all crates and cartons have been received. Before accepting delivery, carefully inspect each carton or crate for visible shipping damage. If any damage is noticed, the carrier should make the proper notation on the delivery receipt acknowledging the damage. Make notations of all damage on all copies of the bill of lading and have all copies countersigned by the delivering carrier. The carrier should also fill out a Carrier Inspection Report. The factory Traffic Department should then be contacted. File claim for damage with the carrier. Physical damage to the unit after acceptance is not the responsibility of Twin City Fan Companies, Ltd.

Unpack each carton or crate and verify that all required parts and proper quantities of each item have been received. Refer to drawings for part descriptions. Report shortages or missing items to your local representative to arrange for replacement parts

Due to availability of carriers and truck space, it is not possible to guarantee that all items will be shipped together. Verification of shipments must be limited to only those items on the bill of lading.

GENERAL INSTALLATION

	CAUTION
<p>Sheet metal parts, screws, clips and similar items inherently have sharp edges. It is necessary that the installer and service personnel exercise caution.</p>	

The installation of this equipment shall be in accordance with the regulations of authorities having jurisdiction and all applicable codes.

This equipment is to be installed by an experienced installation company and fully trained personnel.

The mechanical installation of the exhaust ventilator consists of making final connections between the unit, building services and duct connections.

SERVICE CLEARANCE

Adequate clearance around the unit should be kept for safety, maintenance and proper unit operation.

A minimum clearance of 36" to 48" is recommended to insure proper ventilation. Unit should be installed remote from building air exhausters to inhibit ingestion of exhaust air into building.

Allow a minimum of 24" clearance above the unit for removal of unit top cover. Note: Clearance may have to be increased if using the hinged curb option.

The unit must not be installed under any obstructions.

Figure 1. Service Clearances

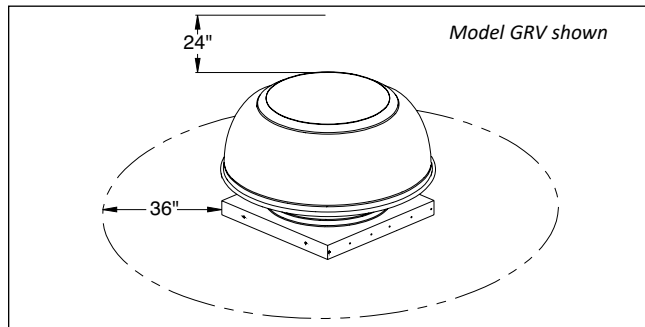

UNIT INSTALLATION

GENERAL

1. The unit should be roof mounted only to an appropriately sized roof curb or duct. See *Roof Curb Installation* on page 3.
2. The base of the curb cap should be horizontal.

INSTALLATION

1. Drill 8 holes (2 per side) into the roof curb through the holes provided in the unit curb cap.
2. Bolt the unit to the roof curb through these holes using 1/4-20 self-tapping screws.

ROOF CURB INSTALLATION

GENERAL

1. Roof curbs are shipped fully assembled. Leveling and mounting on the roof structure are the responsibility of the installing contractor. All curb installations must comply with the established guidelines of the National Roofing Contractors Association.
2. Curb flashing, cant strips and general roofing materials are to be furnished by the contractor. Wood nailing strip is provided with standard curb; gasketing is provided with self-flashing and straight-sided curbs.

NOTICE

Outside dimensions of roof curb top should be $\frac{1}{2}$ " to $1\frac{1}{2}$ " less than inside unit curb cap dimension depending on thickness of flashing material used. If curb hinge accessory is used, specify $1\frac{1}{2}$ " difference.

NOTICE

On self-flashing and straight-sided curbs check top of curb to make sure gasket has been applied properly. Gasket should be firmly applied to top of curb perimeter.

3. The unit and curb accessories are designed to allow vertical duct installation before unit placement. Duct installation after unit placement is not recommended.

INSTALLATION

1. Place curb in proper location over roof opening.
2. Curb must be level. Shim curb as required to level curb.
3. Attach leveled curb to roof structure following industry accepted practice.
4. Install cant strips, roofing materials, flashing and counterflashing in accordance with the established guidelines of the National Roofing Contractors Association. The finished roof, including counterflashing around the curb, must be installed prior to setting unit on the curb.

CURB HINGE INSTALLATION (OPTIONAL - GRV)

GENERAL

1. The curb hinge option assists unit maintenance and cleaning by allowing easy access to the underside of the unit.
2. Pilot holes are provided in the unit curb cap for attaching the curb hinge to the unit as standard. The option is available factory or field installed.

INSTALLATION

1. Ensure the unit will not be restricted from pivoting and that airflow to the unit is not restricted. (See note under "Service Clearance.")
2. Bolt the hinge to the unit curb cap through the holes provided by using $\frac{1}{4}$ -20 self-tapping screws (see Figure 2).
3. Place the unit with the hinge on the roof curb and align hinge holes with roof curb holes.
4. Now bolt the hinge to the roof curb using $\frac{1}{4}$ -20 self-tapping screws (see Figure 2).

Figure 2. Curb Hinge Installation

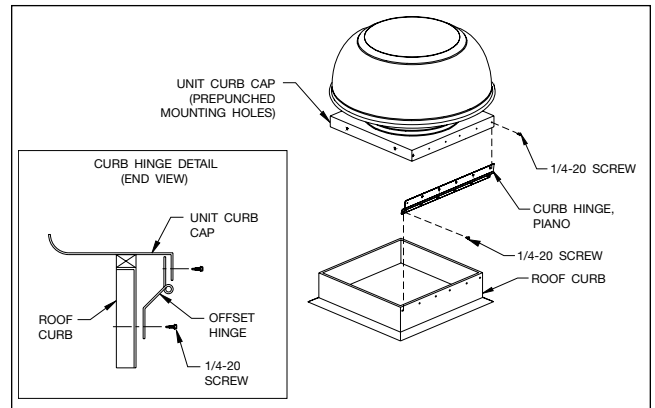

Note: Roof curb to be $1\frac{1}{2}$ " smaller than unit base (curb cap).

INSECT SCREEN (OPTIONAL)

GENERAL

1. The insect screen is a separate part and should not be confused with the bird screen. It contains a finer screen and needs to be installed while the unit is being fastened to the roof curb.

INSTALLATION

1. Place the insect screen assembly on top of the roof curb.
2. When the unit is placed on and being bolted to the roof curb the insect screen will be held in place between the unit curb cap and the roof curb.

BACKDRAFT DAMPER INSTALLATION (OPTIONAL - GRV, TEL, TIL)

1. Damper must be mounted prior to unit installation.
2. Damper should be installed inside curb on a nailing strip or tray (see Figure 3).
3. Be sure knockout for power supply, in one corner of the damper frame, is in the most convenient position for connecting between power source and conduit raceway of unit.
4. Before setting unit on curb, ascertain that the damper is positioned horizontally and operative.
5. Damper motors (optional) are available for 115, or 208-230, 460V, or 575V. When power supply is three-phase, the damper can be connected across any two of the three phases. A power supply of 575V requires a step-down transformer to 115V. Damper motor is energized continuously when open.

Figure 3. Backdraft Damper Installation

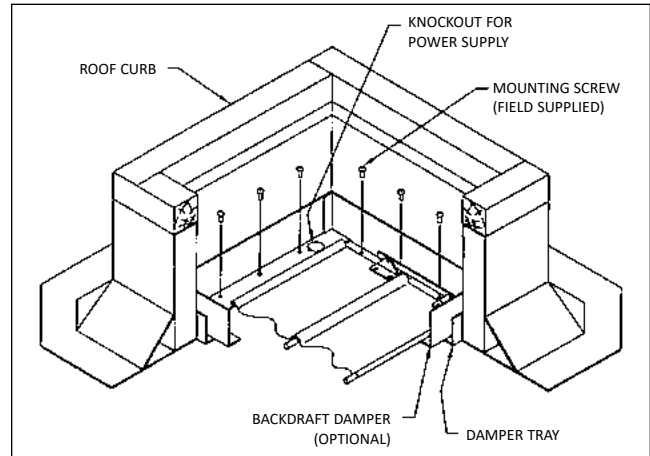

CAUTION

Installation of the damper will differ when using the unit as a relief ventilator versus an intake. The damper must be motorized when used with a GRV as an intake ventilator.

NOTICE

Outside dimensions of damper are $\frac{1}{8}$ " less than specified.

MAINTENANCE

1. Periodically inspect bird or insect screens to ensure they are clean and not restricting airflow.
2. If using a backdraft damper on a GRV, TEL or TIL ventilator, ensure that it can operate freely.
3. Periodically inspect filters on a TIL, if so equipped, to ensure they are clean.

LIMITATION OF WARRANTIES AND CLAIMS

Seller warrants to the original purchaser that the goods sold hereunder shall be free from defects in workmanship and material under normal use and service (except in those cases where the materials are supplied by the buyer) for a period of one year from the date of original installation or eighteen (18) months from the date of shipment, whichever occurs first. The liability of seller under this warranty is limited to replacing, repairing or issuing credit (at cost, F.O.B. factory and at seller's discretion) for any part or parts that are returned by buyer during such period provided that:

- a. seller is notified in writing within ten (10) days following discovery of such defects by buyer or within ten (10) days after such defects should reasonably have been discovered, whichever is less;
- b. the defective unit is returned to seller, transportation charges prepaid by buyer.
- c. payment in full has been received by seller for said products; and
- d. seller's examination of such unit shall disclose to its satisfaction that such defects have not been caused by misuse, neglect, improper installation, repair, alteration, act of God or accident.

No warranty made hereunder shall extend to any seller product whose serial number is altered, effaced or removed. Seller makes no warranty, express or implied, with respect to motors, switches, controls or other components of seller's product, where such components are warranted separately by their respective manufacturers. THIS WARRANTY IS EXPRESSLY IN LIEU OF ALL OTHER WARRANTIES, EXPRESS OR IMPLIED, WHETHER STATUTORY OR OTHERWISE, INCLUDING ANY IMPLIED WARRANTY OF MERCHANTABILITY OR FITNESS FOR A PARTICULAR PURPOSE. In no event shall seller be liable to buyer for indirect, incidental collateral or consequential damages of any kind. (BUYER'S FAILURE TO PAY THE FULL AMOUNT DUE WITHIN SIXTY (60) DAYS OF DATE OF INVOICE SHALL OPERATE TO RELEASE SELLER FROM ANY AND ALL LIABILITY OR OBLIGATION ARISING PURSUANT TO ANY WARRANTY, EXPRESS OR IMPLIED, WHETHER STATUTORY OR OTHERWISE, INCLUDING ANY IMPLIED WARRANTY OR MERCHANTABILITY OR FITNESS FOR A PARTICULAR PURPOSE, MADE IN CONNECTION WITH ANY CONTRACT FORMED HEREUNDER. BUYER AGREES THAT SUCH FAILURE TO PAY SHALL CONSTITUTE A VOLUNTARY WAIVER OF ANY AND ALL SUCH WARRANTIES ARISING PURSUANT TO SUCH CONTACT.)



TWIN CITY FAN & BLOWER | WWW.TCF.COM