



INDUSTRIAL PROCESS AND
COMMERCIAL VENTILATION SYSTEMS

FIXED PITCH PANEL FANS

MODEL TCWP





Arrangement 4
Direct Drive Fan

Motor Side Wire Guard

Provided to completely enclose the motor, drives and support assembly, the motor side wire guard is a square basket type guard.

Fan Side Wire Guard

Provided in a cylindrical shape, the fan side wire guard provides protection while enclosing the panel orifice on the side adjacent to the impeller.

Wall Box Enclosure

Provided to reduce field assembly charges and installation costs, wall box enclosures allow for incorporating the complete fan and shutter in one compact assembly.



Model TCWP

Fixed Pitch

Heavy-Duty Construction

Twin City Fan & Blower fixed pitch panel fans, model TCWP, are constructed of heavy-gauge steel panels with square flanged edges to provide a firm base for the structure of the fan. Sizes 12" through 48" include a deep throated orifice for smooth efficient airflow. Available in either standard or reverse flow, both the motor (direct drive) and shaft and bearing assembly (belt drive) are mounted through the use of heavy-gauge steel plate for rigidity.

Impeller

Designed for high efficiency and low noise/low speed operation, the TCWP impeller provides high performance at an economical rate. Manufactured of lightweight cast aluminum, this 4-bladed impeller is ideal for industrial process work as well as general ventilation. The TCWP impeller combines efficiency and reliability to your impeller fan requirements.

Arrangement 9 Belt Driven

For applications that require the versatility of a belt driven fan, the Arrangement 9 TCWP panel fan is the perfect choice. Driven through either a fixed or adjustable V-belt drive system, the exact point of rating can be simply achieved. Any future change of rating can be accomplished through a simple sheave change.

Shaft & Bearings

Shafts for belt driven TCWP panel fans are ground and polished steel construction machined to a suitable diameter to allow the rotating assembly to operate well below the first critical speed.

Bearings are pillow block, ball or roller type selected for a minimum average life of 200,000 hours. Bearing life is determined in accordance with standards set forth by AFBMA (Anti-Friction Bearing Manufacturers Association).

Motors

Motors for Arrangement 9 TCWP panel fans are standard foot-mounted NEMA design. All of the various enclosures (ODP, totally enclosed, explosion proof, etc.) can be accommodated.

Arrangement 4 Direct Drive

Where maintenance considerations dictate the use of a direct connected fan, the Arrangement 4 TCWP panel fan is the logical choice. Constructed with the fan impeller mounted directly on the motor shaft, this fan provides minimum obstructions in the airstream.

Belt Driven

TCWP 24BTC

Impeller Diameter: 24" Outlet Area: 3.376 ft²

CFM	OV	0" SP		0.125" SP		0.25" SP		0.375" SP		0.5" SP		0.625" SP		0.75" SP		0.875" SP		1" SP		1.25" SP		1.5" SP	
		RPM	BHP	RPM	BHP	RPM	BHP	RPM	BHP	RPM	BHP	RPM	BHP	RPM	BHP	RPM	BHP	RPM	BHP	RPM	BHP	RPM	BHP
3600	1067	648	0.08	824	0.19	973	0.30																
4000	1185	720	0.11	882	0.23	1018	0.35	1152	0.50														
4400	1304	792	0.15	942	0.27	1069	0.41	1190	0.56	1313	0.73												
4800	1422	863	0.19	1004	0.33	1124	0.47	1235	0.63	1346	0.80	1460	1.00										
5200	1541	935	0.25	1067	0.39	1181	0.55	1285	0.71	1387	0.88	1490	1.08	1596	1.31								
5600	1659	1007	0.31	1131	0.46	1239	0.63	1338	0.80	1433	0.98	1528	1.18	1624	1.39	1724	1.65						
6000	1778	1079	0.38	1196	0.54	1299	0.72	1394	0.90	1483	1.09	1572	1.29	1661	1.51	1750	1.74	1843	2.01				
6400	1896	1151	0.46	1262	0.64	1360	0.82	1451	1.01	1536	1.21	1619	1.41	1702	1.63	1786	1.87	1870	2.12				
6800	2015	1223	0.55	1328	0.74	1422	0.93	1509	1.13	1592	1.34	1670	1.55	1748	1.77	1827	2.02	1905	2.27	2065	2.84		
7200	2133	1295	0.66	1395	0.85	1485	1.06	1569	1.27	1648	1.49	1724	1.71	1797	1.93	1871	2.17	1945	2.43	2094	2.99		
7600	2252	1367	0.77	1462	0.98	1549	1.19	1629	1.41	1706	1.64	1779	1.87	1849	2.11	1919	2.35	1989	2.61	2130	3.17	2272	3.79
8000	2370	1439	0.90	1529	1.12	1613	1.34	1691	1.57	1765	1.81	1836	2.05	1904	2.30	1970	2.55	2036	2.81	2170	3.37		
8500	2519	1529	1.08	1614	1.31	1694	1.55	1769	1.79	1839	2.04	1908	2.30	1973	2.55	2037	2.81	2099	3.08	2224	3.65		
9000	2667	1619	1.28	1700	1.52	1776	1.78	1848	2.03	1916	2.30	1981	2.56	2045	2.84	2106	3.11	2165	3.38	2283	3.96		
9500	2815	1709	1.51	1786	1.76	1859	2.03	1928	2.30	1993	2.57	2056	2.85	2117	3.14	2177	3.42	2234	3.71				
10000	2963	1799	1.76	1872	2.03	1942	2.30	2008	2.59	2071	2.87	2132	3.17	2191	3.46	2249	3.77						
10500	3111	1889	2.03	1959	2.32	2026	2.61	2089	2.90	2151	3.20	2209	3.50	2266	3.81								
11000	3259	1979	2.34	2046	2.64	2110	2.94	2171	3.24	2231	3.56	2288	3.88										
11500	3407	2069	2.67	2133	2.98	2194	3.29	2254	3.62														
12000	3556	2159	3.04	2220	3.36	2280	3.69																

TCWP 30BTC

Impeller Diameter: 30" Outlet Area: 5.201 ft²

CFM	OV	0" SP		0.125" SP		0.25" SP		0.375" SP		0.5" SP		0.625" SP		0.75" SP		0.875" SP		1" SP		1.25" SP		1.5" SP	
		RPM	BHP	RPM	BHP	RPM	BHP	RPM	BHP	RPM	BHP	RPM	BHP	RPM	BHP	RPM	BHP	RPM	BHP	RPM	BHP	RPM	BHP
6000	1154	524	0.15	661	0.33	775	0.53	<u>893</u>	<u>0.78</u>														
6500	1250	567	0.19	696	0.38	803	0.59	<u>910</u>	<u>0.84</u>														
7000	1346	611	0.24	733	0.44	834	0.66	932	0.91	<u>1033</u>	<u>1.21</u>												
7500	1442	655	0.30	770	0.51	867	0.74	958	0.99	<u>1050</u>	<u>1.28</u>												
8000	1538	698	0.36	808	0.59	901	0.83	986	1.09	<u>1072</u>	<u>1.38</u>	<u>1160</u>	<u>1.72</u>										
9000	1730	786	0.51	885	0.77	971	1.04	1049	1.32	1125	1.62	<u>1201</u>	<u>1.94</u>	<u>1279</u>	<u>2.31</u>								
10000	1923	873	0.70	964	0.98	1044	1.28	1117	1.59	1186	1.90	1254	2.24	1323	2.60	<u>1392</u>	<u>2.99</u>	<u>1463</u>	<u>3.44</u>				
11000	2115	960	0.93	1044	1.24	1119	1.56	1188	1.90	1253	2.24	1314	2.58	1376	2.96	1439	3.36	<u>1502</u>	<u>3.78</u>	<u>1631</u>	<u>4.74</u>		
12000	2307	1047	1.20	1125	1.54	1195	1.89	1260	2.25	1322	2.63	1380	3.00	1437	3.38	1493	3.78	1551	4.21	<u>1666</u>	<u>5.14</u>	<u>1786</u>	<u>6.22</u>
13000	2500	1135	1.53	1207	1.90	1273	2.27	1334	2.66	1393	3.06	1449	3.46	1502	3.86	1554	4.27	1607	4.72	1713	5.65	<u>1819</u>	<u>6.67</u>
14000	2692	1222	1.92	1289	2.31	1352	2.71	1410	3.12	1466	3.55	1519	3.98	1571	4.41	1620	4.85	1668	5.29	1766	6.24	<u>1864</u>	<u>7.27</u>
15000	2884	1309	2.35	1372	2.77	1431	3.20	1487	3.64	1540	4.09	1591	4.55	1640	5.01	1688	5.48	1734	5.94	1824	6.91	1916	7.96
16000	3076	1397	2.86	1456	3.31	1512	3.76	1565	4.22	1616	4.70	1664	5.18	1712	5.68	1758	6.17	1802	6.66	1887	7.66	1972	8.72
17000	3269	1484	3.43	1540	3.90	1593	4.38	1644	4.88	1693	5.38	1739	5.88	1784	6.40	1828	6.92	1872	7.46	1954	8.50	2034	9.59
18000	3461	1571	4.07	1624	4.57	1675	5.08	1723	5.59	1770	6.12	1815	6.66	1858	7.20	1901	7.75	1942	8.30	2022	9.41	2099	10.54
19000	3653	1658	4.78	1709	5.32	1757	5.85	1804	6.40	1849	6.95	1892	7.51	1934	8.08	1974	8.64	2014	9.23	2092	10.41		
20000	3845	1746	5.59	1794	6.14	1840	6.71	1884	7.27	1928	7.86	1969	8.43	2010	9.03	2049	9.63	2088	10.24				
21000	4038	1833	6.47	1879	7.05	1923	7.64	1966	8.24	2007	8.84	2048	9.46	2087	10.07								
22000	4230	1920	7.43	1964	8.04	2006	8.66	2047	9.28	2088	9.92												
23000	4422	2008	8.50	2049	9.13	2090	9.77																

TCWP 36BTC

Impeller Diameter: 36" Outlet Area: 7.42 ft²

CFM	OV	0" SP		0.125" SP		0.25" SP		0.375" SP		0.5" SP		0.625" SP		0.75" SP		0.875" SP		1" SP		1.25" SP		1.5" SP	
		RPM	BHP	RPM	BHP	RPM	BHP	RPM	BHP	RPM	BHP	RPM	BHP	RPM	BHP	RPM	BHP	RPM	BHP	RPM	BHP	RPM	BHP
7000	944	468	0.12	591	0.28	693	0.46	<u>790</u>	<u>0.68</u>														
8000	1078	535	0.18	646	0.36	738	0.56	<u>825</u>	<u>0.78</u>	<u>909</u>	<u>1.04</u>	<u>993</u>	<u>1.34</u>										
9000	1213	602	0.26	703	0.46	789	0.68	<u>867</u>	<u>0.91</u>	<u>944</u>	<u>1.17</u>	<u>1018</u>	<u>1.46</u>	1093	1.79								
10000	1348	669	0.35	762	0.57	842	0.81	914	1.06	984	1.33	<u>1053</u>	<u>1.62</u>	1120	1.94	1187	2.30	1253	2.68				
11000	1483	736	0.47	822	0.71	896	0.97	965	1.24	1029	1.52	1093	1.82	<u>1155</u>	<u>2.14</u>	<u>1216</u>	<u>2.49</u>	1277	2.87				
12000	1618	803	0.61	883	0.87	953	1.15	1018	1.44	1078	1.73	1137	2.05	1195	2.38	<u>1252</u>	<u>2.73</u>	<u>1308</u>	<u>3.10</u>	1420	3.94		
13000	1752	873	0.78	944	1.06	1011	1.36	1072	1.67	1130	1.98	1185	2.31	1238	2.65	<u>1292</u>	<u>3.01</u>	<u>1345</u>	<u>3.39</u>	<u>1449</u>	<u>4.21</u>	1552	5.14
14000	1887	936	0.97	1006	1.27	1069	1.59	1127	1.91	1183	2.26	1235	2.60	1286	2.95	1336	3.33	<u>1386</u>	<u>3.72</u>	<u>1484</u>	<u>4.54</u>	<u>1579</u>	<u>5.45</u>
15000	2022	1003	1.19	1069	1.52	1129	1.85	1184	2.20	1237	2.56	1287	2.92	1336	3.30	1383	3.68	1430	4.08	1522	4.92	1613	5.83
16000	2157	1070	1.45	1132	1.79	1189	2.15	1242	2.51	1292	2.89	1341	3.28	1388	3.67	1432	4.06	1477	4.48	1564	5.34	1651	6.27
17000	2292	1137	1.74	1195	2.10	1250	2.48	1301	2.86	1349	3.26	1396	3.67	1441	4.09	1484	4.50	1526	4.92	1609	5.81	1691	6.75
18000	2427	1204	2.07	1259	2.45	1311	2.84	1360	3.25	1407	3.67	1451	4.09	1495	4.53	1537	4.97	1577	5.40	1656	6.31	1734	7.27
19000	2561	1271	2.43	1323	2.83	1373	3.25	1420	3.67	1465	4.11	1508	4.55	1550	5.01	1590	5.47	1630	5.93	1706	6.87	1780	7.85
20000	2696	1338	2.84	1388	3.26	1435	3.69	1481	4.14	1524	4.59	1566	5.06	1606	5.53	1645	6.01	1683	6.49	1757	7.48		
21000	2831	1405	3.28	1452	3.72	1498	4.18	1542	4.65	1584	5.12	1624	5.										

Belt Driven

TCWP 42BTC

Impeller Diameter: 42.5" Outlet Area: 10.03 ft²

CFM	OV	0" SP		0.125" SP		0.25" SP		0.375" SP		0.5" SP		0.625" SP		0.75" SP		0.875" SP		1" SP		1.25" SP		1.5" SP	
		RPM	BHP	RPM	BHP	RPM	BHP	RPM	BHP	RPM	BHP	RPM	BHP	RPM	BHP	RPM	BHP	RPM	BHP	RPM	BHP	RPM	BHP
9000	898	442	0.12	607	0.33	<u>742</u>	<u>0.59</u>	<u>857</u>	<u>0.88</u>	960	1.22	1058	1.61	1149	2.04	1235	2.51	1315	3.00				
10000	998	491	0.16	642	0.39	770	0.66	<u>881</u>	<u>0.97</u>	981	1.32	1073	1.70	1160	2.13	1244	2.60	1323	3.10	1470	4.19	1602	5.36
11000	1098	540	0.22	680	0.46	800	0.75	<u>908</u>	<u>1.08</u>	<u>1004</u>	<u>1.43</u>	1093	1.82	1176	2.24	1256	2.71	1333	3.21	1478	4.31	1610	5.51
12000	1198	589	0.28	719	0.55	833	0.85	936	1.19	<u>1029</u>	<u>1.56</u>	<u>1116</u>	<u>1.96</u>	1196	2.39	1272	2.84	1346	3.34	1487	4.44	1618	5.65
13000	1297	638	0.36	760	0.65	867	0.96	966	1.31	<u>1056</u>	<u>1.70</u>	<u>1140</u>	<u>2.11</u>	<u>1219</u>	<u>2.55</u>	1292	3.01	1363	3.50	1499	4.59	1628	5.82
14000	1397	687	0.44	802	0.76	903	1.08	997	1.45	1085	1.85	<u>1166</u>	<u>2.28</u>	<u>1243</u>	<u>2.73</u>	<u>1316</u>	<u>3.21</u>	1384	3.70	1514	4.78	1639	5.99
15000	1497	736	0.55	845	0.89	940	1.22	1030	1.60	1115	2.02	1194	2.46	<u>1268</u>	<u>2.92</u>	<u>1340</u>	<u>3.42</u>	<u>1407</u>	<u>3.92</u>	1533	5.00	1653	6.20
16000	1597	785	0.66	888	1.02	979	1.38	1065	1.78	1146	2.20	1223	2.66	1296	3.14	<u>1365</u>	<u>3.64</u>	<u>1431</u>	<u>4.16</u>	1555	5.26	1671	6.46
17000	1697	834	0.79	932	1.18	1019	1.56	1101	1.97	1179	2.40	1253	2.87	1324	3.37	<u>1392</u>	<u>3.89</u>	<u>1456</u>	<u>4.42</u>	<u>1579</u>	<u>5.55</u>	1692	6.75
18000	1796	883	0.94	976	1.35	1059	1.75	1138	2.17	1213	2.62	1285	3.10	1354	3.62	1420	4.15	<u>1483</u>	<u>4.70</u>	<u>1603</u>	<u>5.85</u>	1715	7.08
19000	1896	932	1.11	1021	1.54	1101	1.96	1176	2.40	1248	2.86	1318	3.36	1385	3.88	1449	4.42	1511	4.99	<u>1628</u>	<u>6.17</u>	<u>1738</u>	<u>7.42</u>
20000	1996	981	1.29	1066	1.75	1143	2.19	1215	2.64	1285	3.13	1352	3.63	1417	4.16	1479	4.72	1540	5.31	<u>1655</u>	<u>6.53</u>	<u>1763</u>	<u>7.80</u>
21000	2096	1030	1.49	1111	1.97	1186	2.45	1255	2.91	1322	3.41	1387	3.93	1450	4.47	1511	5.04	1570	5.64	1683	6.89	<u>1788</u>	<u>8.19</u>
22000	2196	1079	1.72	1157	2.22	1229	2.72	1296	3.21	1360	3.71	1423	4.24	1484	4.80	1543	5.38	1601	5.99	1711	7.27	<u>1815</u>	<u>8.61</u>
24000	2395	1177	2.23	1249	2.78	1316	3.32	1379	3.86	1439	4.39	1498	4.96	1555	5.54	1611	6.14	1666	6.78	1771	8.10		
26000	2595	1276	2.84	1342	3.43	1405	4.03	1464	4.60	1521	5.18	1576	5.77	1630	6.38	1683	7.02	1735	7.68				
28000	2794	1374	3.55	1436	4.19	1495	4.83	1551	5.46	1605	6.08	1656	6.69	1707	7.33	1757	8.00	1806	8.68				
30000	2994	1472	4.36	1530	5.05	1586	5.74	1639	6.41	1690	7.08	1739	7.74	1787	8.41								
32000	3194	1570	5.29	1625	6.03	1677	6.76	1728	7.49	1777	8.21												
34000	3393	1668	6.35	1720	7.13	1769	7.90	1818	8.69														

TCWP 48BTC

Impeller Diameter: 48.5" Outlet Area: 13.03 ft²

CFM	OV	0" SP		0.125" SP		0.25" SP		0.375" SP		0.5" SP		0.625" SP		0.75" SP		0.875" SP		1" SP		1.25" SP		1.5" SP	
		RPM	BHP	RPM	BHP	RPM	BHP	RPM	BHP	RPM	BHP	RPM	BHP	RPM	BHP	RPM	BHP	RPM	BHP	RPM	BHP	RPM	BHP
9000	691	263	0.08	380	0.30	481	0.58																
10000	768	293	0.12	400	0.34	<u>492</u>	<u>0.64</u>																
11000	845	322	0.15	422	0.40	507	0.71	589	1.07														
12000	922	351	0.20	445	0.46	524	0.78	<u>600</u>	<u>1.16</u>														
13000	998	380	0.25	469	0.54	543	0.86	<u>614</u>	<u>1.25</u>	684	1.69												
14000	1075	410	0.32	493	0.62	563	0.96	<u>630</u>	<u>1.36</u>	<u>694</u>	<u>1.80</u>	759	2.29										
15000	1152	439	0.39	518	0.71	585	1.06	647	1.46	<u>709</u>	<u>1.93</u>	<u>769</u>	<u>2.42</u>										
16000	1229	468	0.47	544	0.82	607	1.18	666	1.59	<u>724</u>	<u>2.06</u>	<u>781</u>	<u>2.57</u>	838	3.11								
17000	1306	497	0.57	569	0.93	630	1.31	687	1.74	742	2.21	<u>796</u>	<u>2.73</u>	<u>849</u>	<u>3.28</u>	902	3.86						
18000	1382	527	0.68	595	1.06	654	1.45	708	1.89	760	2.37	<u>812</u>	<u>2.90</u>	<u>862</u>	<u>3.46</u>	<u>913</u>	<u>4.06</u>	963	4.68				
20000	1536	585	0.93	648	1.36	703	1.79	753	2.24	801	2.75	848	3.29	<u>894</u>	<u>3.87</u>	<u>940</u>	<u>4.50</u>	<u>985</u>	<u>5.14</u>	1075	6.51		
22000	1690	644	1.24	702	1.71	753	2.18	800	2.66	845	3.19	888	3.75	930	4.34	973	4.99	<u>1014</u>	<u>5.65</u>	<u>1096</u>	<u>7.06</u>	1179	8.59
24000	1843	702	1.60	756	2.12	804	2.64	848	3.15	891	3.70	931	4.28	970	4.89	1009	5.54	1048	6.23	<u>1125</u>	<u>7.71</u>	<u>1200</u>	<u>9.26</u>
26000	1997	761	2.04	811	2.60	856	3.16	898	3.71	938	4.28	976	4.88	1013	5.52	1050	6.20	1086	6.90	<u>1157</u>	<u>8.39</u>		
28000	2151	819	2.54	866	3.15	909	3.75	949	4.35	987	4.95	1023	5.57	1058	6.23	1093	6.94	1126	7.64	1193	9.17		
30000	2304	878	3.13	921	3.77	962	4.42	1000	5.06	1036	5.70	1071	6.35	1105	7.04	1138	7.76	1170	8.50				
32000	2458	936	3.80	977	4.48	1016	5.18	1053	5.87	1087	6.54	1120	7.23	1152	7.93	1184	8.68	1215	9.45				
34000	2611	995	4.56	1034	5.30	1070	6.02	1105	6.75	1139	7.49	1170	8.20	1201	8.93								
36000	2765	1053	5.41	1090	6.18	1125	6.96	1159	7.75	1191	8.52												
38000	2919	1112	6.37	1147	7.19	1180	8.00	1212	8.81														

Underlined figures indicate maximum static pressure.

Direct Drive

TCWP 12DTC

Impeller Diameter: 12" Outlet Area: 0.85 ft²

PROP	RPM	HP	0" SP	0.125" SP	0.25" SP	0.375" SP	0.5" SP	0.625" SP	0.75" SP	0.875" SP	1" SP	1.25" SP	1.5" SP
			CFM BHP	CFM BHP	CFM BHP	CFM BHP	CFM BHP	CFM BHP	CFM BHP	CFM BHP	CFM BHP	CFM BHP	CFM BHP
12DTC	1170	1/12	686 0.01										
12DTC	1750	1/12	1026 0.04	899 0.06	703 0.06								
12DTC	3500	1/2	2051 0.34	1993 0.37	1932 0.04	1867 0.42	1797 0.44	1721 0.46	1636 0.47	1537 0.48	1406 0.47		

TCWP 14DTC

Impeller Diameter: 14" Outlet Area: 1.19 ft²

PROP	RPM	HP	0" SP	0.125" SP	0.25" SP	0.375" SP	0.5" SP	0.625" SP	0.75" SP	0.875" SP	1" SP	1.25" SP	1.5" SP
			CFM BHP	CFM BHP	CFM BHP	CFM BHP	CFM BHP	CFM BHP	CFM BHP	CFM BHP	CFM BHP	CFM BHP	CFM BHP
14DTC	1170	1/12	1204 0.03	<u>701 0.03</u>									
14DTC	1750	1/8	1801 0.10	1547 0.10	<u>1181 0.10</u>								
14DTC	3500	3/4	3602 0.77	3485 0.79	3363 0.80	3233 0.82	3094 0.82	2943 0.82	2778 0.81	2593 0.81	<u>2363 0.81</u>		

TCWP 16DTC

Impeller Diameter: 16" Outlet Area: 1.53 ft²

PROP	RPM	HP	0" SP	0.125" SP	0.25" SP	0.375" SP	0.5" SP	0.625" SP	0.75" SP	0.875" SP	1" SP	1.25" SP	1.5" SP
			CFM BHP	CFM BHP	CFM BHP	CFM BHP	CFM BHP	CFM BHP	CFM BHP	CFM BHP	CFM BHP	CFM BHP	CFM BHP
16DTC	1170	1/12	1946 0.08	1497 0.08									
16DTC	1750	1/4	2910 0.25	2586 0.27	2207 0.26								
16DTC	3500	2	5820 2.02	5666 2.05	5507 2.08	5343 2.10	5172 2.12	4996 2.14	4618 2.14	4415 2.11	3958 2.00		

TCWP 18DTC

Impeller Diameter: 18" Outlet Area: 1.92 ft²

PROP	RPM	HP	0" SP	0.125" SP	0.25" SP	0.375" SP	0.5" SP	0.625" SP	0.75" SP	0.875" SP	1" SP	1.25" SP	1.5" SP
			CFM BHP	CFM BHP	CFM BHP	CFM BHP	CFM BHP	CFM BHP	CFM BHP	CFM BHP	CFM BHP	CFM BHP	CFM BHP
18DTC	880	1/12	1760 0.03										
18DTC	1170	1/12	2340 0.07	1759 0.08									
18DTC	1750	1/4	3500 0.22	3130 0.24	2734 0.26	2302 0.27							

TCWP 21DTC

Impeller Diameter: 21" Outlet Area: 2.61 ft²

PROP	RPM	HP	0" SP	0.125" SP	0.25" SP	0.375" SP	0.5" SP	0.625" SP	0.75" SP	0.875" SP	1" SP	1.25" SP	1.5" SP
			CFM BHP	CFM BHP	CFM BHP	CFM BHP	CFM BHP	CFM BHP	CFM BHP	CFM BHP	CFM BHP	CFM BHP	CFM BHP
21DTC	880	1/8	3472 0.11	2803 0.13									
21DTC	1170	1/3	4617 0.26	4169 0.30	3576 0.31								
21DTC	1750	1	6906 0.88	6624 0.94	6315 0.98	5962 1.02	5554 1.04	5107 1.06	<u>4485 1.06</u>				

Underlined figures indicate maximum static pressure.

Direct Drive

TCWP 24DTC

Impeller Diameter: 24" Outlet Area: 3.376 ft²

PROP	RPM	HP	0" SP		0.125" SP		0.25" SP		0.375" SP		0.5" SP		0.625" SP		0.75" SP		0.875" SP		1" SP		1.25" SP		1.5" SP		
			CFM	BHP	CFM	BHP	CFM	BHP	CFM	BHP	CFM	BHP	CFM	BHP	CFM	BHP	CFM	BHP	CFM	BHP	CFM	BHP	CFM	BHP	CFM
24DTC	880	1/4	4900	0.17	4001	0.20																			
24DTC	1170	1/2	6515	0.41	5862	0.44	5133	0.46	<u>4072</u>	<u>0.47</u>															
24DTC	1750	1 1/2	9744	1.37	9318	1.42	8875	1.46	8418	1.51	7934	1.54	7363	1.56	6677	1.57	<u>5829</u>	<u>1.56</u>							

TCWP 30DTC

Impeller Diameter: 30" Outlet Area: 5.20 ft²

PROP	RPM	HP	0" SP		0.125" SP		0.25" SP		0.375" SP		0.5" SP		0.625" SP		0.75" SP		0.875" SP		1" SP		1.25" SP		1.5" SP		
			CFM	BHP	CFM	BHP	CFM	BHP	CFM	BHP	CFM	BHP	CFM	BHP	CFM	BHP	CFM	BHP	CFM	BHP	CFM	BHP	CFM	BHP	CFM
30DTC	880	3/4	10072	0.62	8982	0.66	7665	0.69	5709	0.67															
30DTC	1170	1 1/2	13391	.45	12598	1.51	11736	1.56	10778	1.60	9624	1.62	8147	1.59											
30DTC	1750	5	20029	4.84	19510	4.93	18973	5.02	18416	5.10	17836	5.18	17233	5.25	16600	5.32	15919	5.37	15172	5.40	13439	5.40	<u>11133</u>	<u>5.26</u>	

TCWP 36DTC

Impeller Diameter: 36" Outlet Area: 7.42 ft²

PROP	RPM	HP	0" SP		0.125" SP		0.25" SP		0.375" SP		0.5" SP		0.625" SP		0.75" SP		0.875" SP		1" SP		1.25" SP		1.5" SP		
			CFM	BHP	CFM	BHP	CFM	BHP	CFM	BHP	CFM	BHP	CFM	BHP	CFM	BHP	CFM	BHP	CFM	BHP	CFM	BHP	CFM	BHP	CFM
36DTC	880	1	13157	0.81	11957	0.86	10704	0.92	9286	0.95															
36DTC	1170	3	17493	1.90	16599	1.97	15683	2.05	14750	2.13	13764	2.19	12704	.23	11385	2.23									
36DTC	1750	7 1/2	26164	6.35	25571	6.46	24971	6.58	24365	6.69	23751	6.81	23132	6.92	22510	7.03	21878	7.15	21227	7.25	19863	7.39	18353	7.47	

TCWP 42DTC

Impeller Diameter: 42.5" Outlet Area: 10.03 ft²

PROP	RPM	HP	0" SP		0.125" SP		0.25" SP		0.375" SP		0.5" SP		0.625" SP		0.75" SP		0.875" SP		1" SP		1.25" SP		1.5" SP		
			CFM	BHP	CFM	BHP	CFM	BHP	CFM	BHP	CFM	BHP	CFM	BHP	CFM	BHP	CFM	BHP	CFM	BHP	CFM	BHP	CFM	BHP	CFM
42DTC	880	1	17937	0.93	15810	1.00	13359	1.00	<u>9944</u>	<u>0.97</u>															
42DTC	1170	3	23848	2.19	22281	2.30	20632	2.35	18848	2.36	16731	2.35	<u>14143</u>	<u>2.31</u>	10664	2.20									
42DTC	1750	7 1/2	35670	7.33	34638	7.51	33581	7.65	32497	7.77	31391	7.85	30263	7.88	29085	7.90	27814	7.90	26436	7.88	23304	7.81	<u>19475</u>	<u>7.60</u>	

TCWP 48DTC

Impeller Diameter: 48.5" Outlet Area: 13.03 ft²

PROP	RPM	HP	0" SP		0.125" SP		0.25" SP		0.375" SP		0.5" SP		0.625" SP		0.75" SP		0.875" SP		1" SP		1.25" SP		1.5" SP		
			CFM	BHP	CFM	BHP	CFM	BHP	CFM	BHP	CFM	BHP	CFM	BHP	CFM	BHP	CFM	BHP	CFM	BHP	CFM	BHP	CFM	BHP	CFM
48DTC	880	5	30075	3.16	28510	3.30	26907	3.42	25280	3.50	23544	3.57	21638	3.66	19148	3.69									
48DTC	1170	10	39986	7.42	38815	7.62	37629	7.80	36425	7.96	35209	8.09	33987	8.20	32728	8.29	31399	8.39	30017	8.50	26729	8.67			

Underlined figures indicate maximum static efficiency.

Arrangement 9, Belt Driven

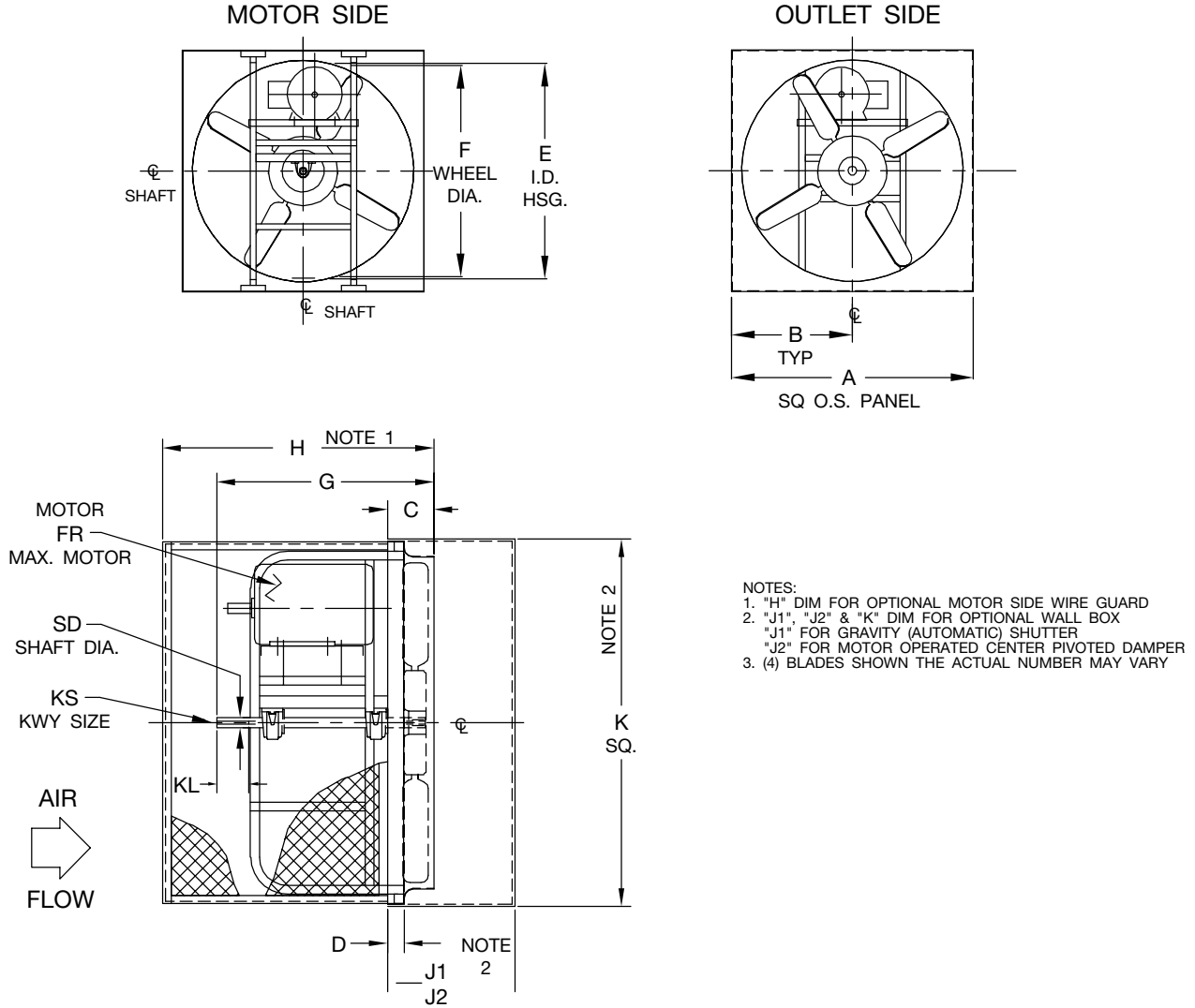

FAN SIZE	24	30	36	42	48
A	30.00	36.00	42.00	48.00	54.00
B	15.00	18.00	21.00	24.00	27.00
C	7.75	8.38	8.25	8.25	8.75
D	2.75	2.75	2.75	2.75	2.75
E	24.88	30.88	36.88	42.88	48.88
F	24.38	30.25	36.13	42.50	48.50
FR	145T	184T	215T	215T	256T
G	20.75	26.75	26.63	26.13	32.00
H	27.37	33.38	32.75	32.25	38.25
J(1)	13.50	14.00	14.00	14.00	16.00
J(2)	24.00	24.00	26.00	26.00	26.00
K	30.25	36.25	42.25	48.25	54.25
KL	2.75	3.38	3.38	3.38	4.00
KS	.25 x .13	.25 x .13	.25 x .13	.38 x .19	.38 x .19
SD	1.000	1.187	1.187	1.437	1.437

AC13643G

DRAWING IS NOT TO BE USED FOR CONSTRUCTION. CERTIFIED DRAWING AVAILABLE UPON REQUEST.

Arrangement 4, Direct Drive Sizes 12-16

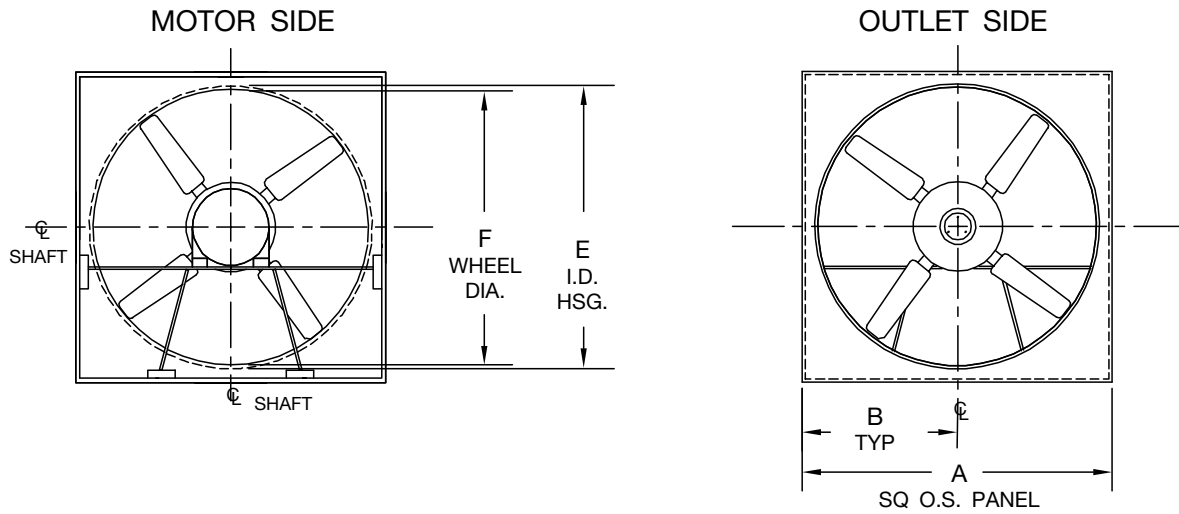

NOTES:

1. "H" DIM FOR OPTIONAL MOTOR SIDE WIRE GUARD
2. "J1", "J2" & "K" DIM FOR OPTIONAL WALL BOX
3. "J2" FOR MOTOR OPERATED CENTER PIVOTED DAMPER
4. 3, (4) BLADES SHOWN THE ACTUAL NUMBER MAY VARY

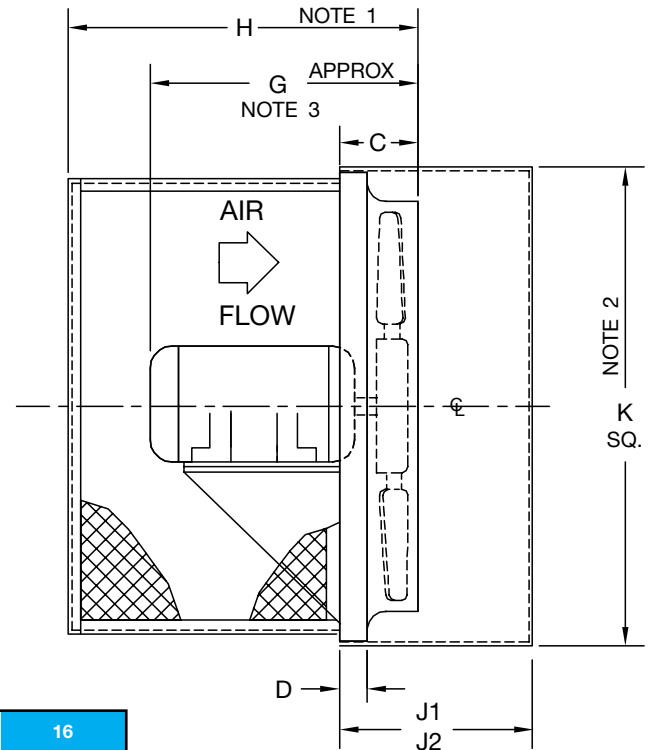

FAN SIZE	12	14	16
A	16.00	18.00	20.00
B	8.00	9.00	10.00
C	2.38	3.88	4.38
D	1.00	1.00	1.00
E	12.50	14.75	16.75
F	12.00	14.00	16.00
FR	145T	145T	145T
G	14.38	15.63	15.88
H	19.38	20.63	20.88
J1	13.00	13.50	13.50
J2	21.00	21.00	22.00
K	16.25	18.25	20.25

AC13645D

DRAWING IS NOT TO BE USED FOR CONSTRUCTION. CERTIFIED DRAWING AVAILABLE UPON REQUEST.

Arrangement 4, Direct Drive Sizes 18-60

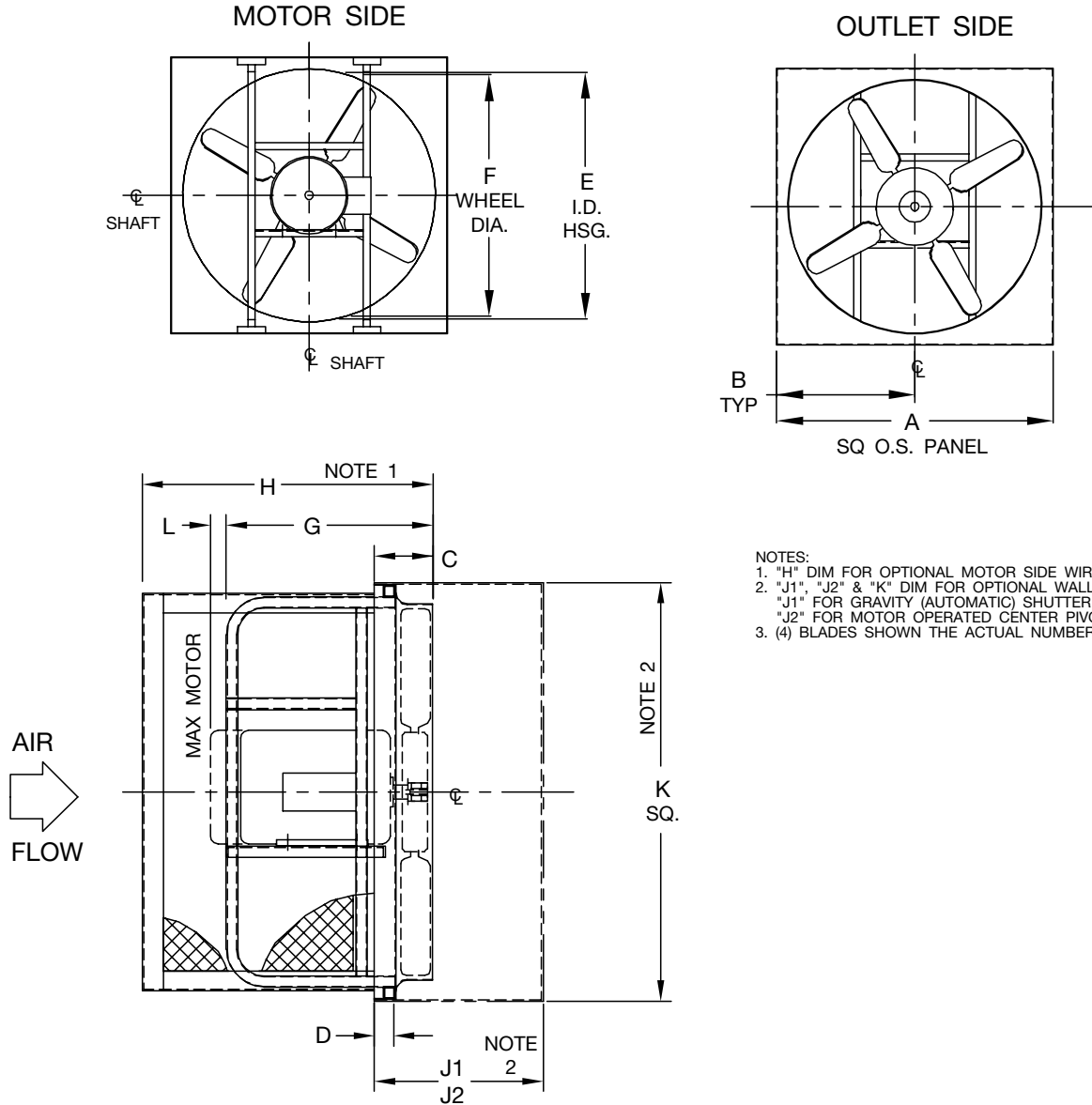

FAN SIZE	18	21	24	30	36	42	48	54	60
A	22.00	25.00	30.00	36.00	42.00	48.00	54.00	60.00	66.00
B	11.00	12.50	15.00	18.00	21.00	24.00	27.00	30.00	33.00
C	4.81	7.13	7.75	8.38	8.25	8.25	8.75	8.75	8.75
D	2.75	2.75	2.75	2.75	2.75	2.75	2.75	2.75	2.75
E	18.75	21.88	24.88	30.88	36.88	42.88	48.88	55.00	61.00
F	18.38	21.38	24.38	30.25	36.13	42.50	48.50	54.50	60.50
FR	184T	184T	215T	215T	215T	256T	286T	286T	286T
G	14.94	18.00	18.06	24.77	25.31	28.31	28.56	30.56	30.56
H	25.06	24.75	27.50	30.25	29.63	33.88	37.63	37.50	37.50
J1	13.50	13.50	13.50	14.00	14.00	14.00	16.00	16.00	16.00
J2	22.00	24.00	24.00	24.00	26.00	26.00	26.00	26.00	26.00
K	22.25	25.25	30.25	36.25	42.25	48.25	54.25	60.25	66.31
L	3.25	N/A	2.56	N/A	N/A	4.31	2.81	0.69	0.44

AC14457B

DRAWING IS NOT TO BE USED FOR CONSTRUCTION. CERTIFIED DRAWING AVAILABLE UPON REQUEST.

Wall Box Enclosure

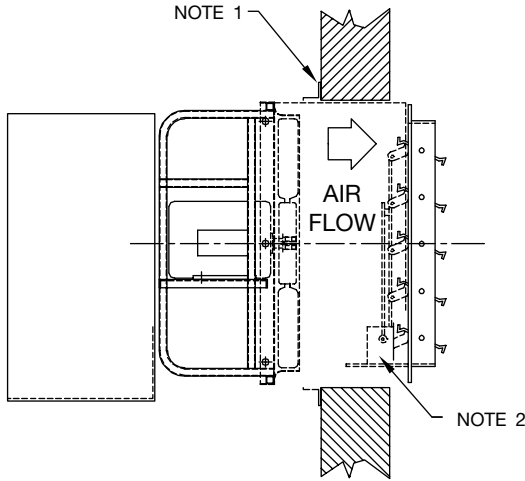

**EXHAUST
(STANDARD FLOW FAN)**

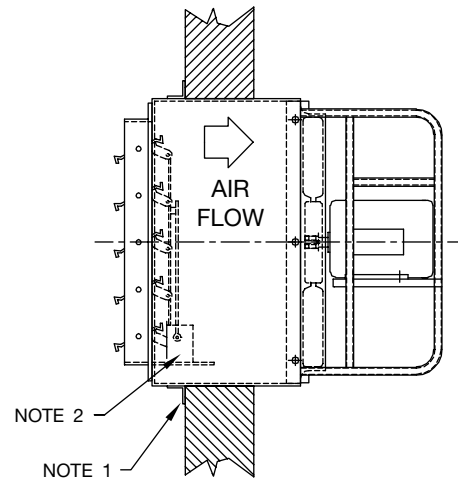

**SUPPLY
(REVERSE FLOW FAN)**

- NOTES:
1. ANGLE FLANGE MOUNTING IS AN OPTION & MUST BE LOCATED BY CUSTOMER
 2. DAMPER IS PROVIDED AS ACCESSORY EQUIPMENT. DAMPER CAN BE EITHER GRAVITY (BACKDRAFT) OR MOTOR OPERATED TYPE. (AS SHOWN)
 3. C1 DIM FOR GRAVITY SHUTTER
C2 DIM FOR MOTOR OPERATED SHUTTER

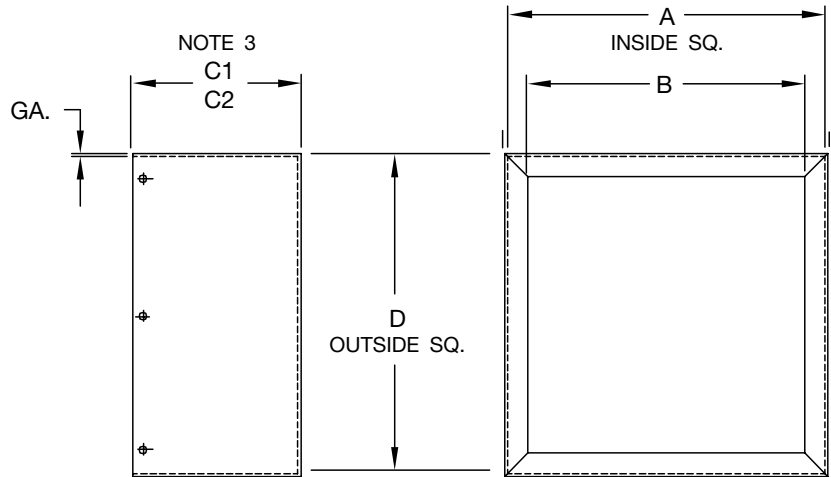

SIZE	12	14	16	18	21	24	30	36	42	48	54	60	66	72	84
A	16.13	18.13	20.13	22.13	25.13	30.13	36.13	42.13	48.13	54.13	60.13	66.13	72.13	84.63	96.63
B	12.13	14.13	16.13	18.13	21.13	26.13	32.13	38.13	44.13	50.13	56.13	62.13	68.13	80.63	80.63
C1	13.00	13.50	13.50	13.50	13.50	13.50	14.00	14.00	14.00	16.00	16.00	16.00	16.00	16.00	16.00
C2	21.00	21.00	22.00	22.00	24.00	24.00	24.00	26.00	26.00	26.00	26.00	26.00	28.00	28.00	28.00
D	16.25	18.25	20.25	22.25	25.25	30.25	36.25	42.25	48.25	54.25	60.25	66.31	72.31	84.88	96.88
GA.	16	16	16	16	16	16	14	14	14	14	14	12	12	10	10

AC13717B

DRAWING IS NOT TO BE USED FOR CONSTRUCTION. CERTIFIED DRAWING AVAILABLE UPON REQUEST.

Belt Driven - Arrangement 9

Fans shall be Model TCWP Panel Fans as manufactured by Twin City Fan & Blower, Minneapolis, Minnesota.

IMPELLERS — Impellers shall be cast aluminum alloy construction positively attached to the shaft via a taper lock bushing to assure positive rotation. Impellers shall be machined to the proper diameter and statically balanced.

PANEL — Panel shall be constructed of heavy-gauge steel with square flanged edges. A deep-throated orifice shall be provided for smooth, efficient airflow. Heavy-gauge steel plate shall support the motor and the shaft and bearing assembly. Use of lightweight tubing shall not be acceptable for motor mounting purposes.

BEARING — The rotating assembly shall be supported by two heavy-duty pillow block ball or roller type bearings. The bearings shall be of a self-aligning type and designed for a minimum average life of 200,000 hours based on AFBMA rating designations.

SHAFT — The fan shaft shall be ground and polished, hot-rolled steel precisely turned and ring gauged for accuracy. The entire rotating assembly shall be designed to limits that insure the critical speed of at least 42% greater than the fan operating speed.

DRIVES — The fan shall be equipped with (fixed, adjustable) pitch V-belt drive for operation at the required RPM. V-belt drive is to be selected with a (1.2, 1.5) safety factor based on the fan brake horsepower.

MOTORS — Fan motors shall be standard NEMA design in an (ODP, TEFC, explosion-proof, etc.) type enclosure. Motor horsepower rating shall be greater than the fan brake horsepower rating as motor service factor cannot be utilized to achieve horsepower requirements. V-belt drive losses must be taken into account in the calculation of motor horsepower.

ACCESSORIES — Accessories such as wire guards, wall box enclosures, power roof vent construction, etc., shall be provided by the fan manufacturer, maintaining proper sizing and fit-up along with one-source responsibility.

COMPLETED FAN UNITS — All fans prior to shipment shall be completely assembled and test run as a unit at the operating speed. Final balance of the completed fan assembly shall be taken by electronic type equipment and records maintained of the vibration readings in the axial, vertical and horizontal planes on each of the bearings. A written copy of this record shall be available upon request.

Direct Drive - Arrangement 4

Fans shall be Model TCWP Panel Fans as manufactured by Twin City Fan & Blower, Minneapolis, Minnesota.

IMPELLERS — Impellers shall be cast aluminum alloy construction positively attached to the shaft via a taper lock bushing to assure positive rotation. Impellers shall be machined to the proper diameter and statically balanced.

PANEL — Panel is to be constructed of heavy-gauge steel with square flanged edges. A deep-throated orifice shall be provided for smooth, efficient airflow. Heavy-gauge steel plate shall support the motor. Use of lightweight tubing shall not be acceptable for motor mounting purposes.

MOTORS — Fan motors are to be standard NEMA design in an (ODP, TEFC, explosion-proof, etc.) type enclosure.

ACCESSORIES — Accessories such as wire guards, wall box enclosures, power roof vent construction, etc., shall be provided by the fan manufacturer, maintaining proper sizing and fit-up along with one-source responsibility.

COMPLETED FAN UNITS — All fans prior to shipment shall be completely assembled and test run as a unit at the operating speed. Final balance of the completed fan assembly shall be taken by electronic type equipment and records maintained of the vibration readings in the axial, vertical and horizontal planes on each of the bearings. A written copy of this record shall be available upon request.

INDUSTRIAL PROCESS AND COMMERCIAL VENTILATION SYSTEMS

CENTRIFUGAL FANS | UTILITY SETS | PLENUM & PLUG FANS | INLINE CENTRIFUGAL FANS
MIXED FLOW FANS | TUBEAXIAL & VANEAXIAL FANS | WALL MOUNTED FANS | ROOF VENTILATORS
CENTRIFUGAL ROOF & WALL EXHAUSTERS | CEILING VENTILATORS | GRAVITY VENTILATORS | DUCT BLOWERS
RADIAL BLADED FANS | RADIAL TIP FANS | HIGH EFFICIENCY INDUSTRIAL FANS | PRESSURE BLOWERS
LABORATORY EXHAUST FANS | FILTERED SUPPLY FANS | MANCOOLERS | FIBERGLASS FANS | CUSTOM FANS



TWIN CITY FAN & BLOWER
WWW.TCF.COM

5959 TRENTON LANE N | MINNEAPOLIS, MN 55442 | PHONE: 763-551-7600 | FAX: 763-551-7601

©2018 Twin City Fan Companies, Ltd., Minneapolis, MN. All rights reserved. Catalog illustrations cover the general appearance of Twin City Fan & Blower products at the time of publication and we reserve the right to make changes in design and construction at any time without notice.