

FG7 Tubeaxial Fans

The installation of FRP tubeaxial fans requires some special considerations. The material is very strong and more flexible than steel. Large FRP fans with heavy motors should not be expected to support themselves by the flange mounting alone. A fan mounted in the vertical position should not be mounted to support a heavy stack without some reinforcement. It is usually satisfactory to mount fans having motors up to 3 HP by the flanges alone. Match drill the flanges with the mating duct flange using eight equally spaced holes, $\frac{7}{16}$ " diameter, to accept a $\frac{3}{8}$ " bolt. Since fiberglass is used only for corrosion resistance, it is recommended that stainless steel bolts be used. Use a large washer under the head and nut to increase the load bearing area and do not tighten these to the point of crushing the flanges. If the fan has a 5 HP or larger motor, it is good practice to attach a brace or hanger rod to the outer edge of the motor base plate to take some of the weight. If the fan is to be mounted on the roof with a high discharge stack, brace the stack just above the fan so that not all of the stack weight is carried on the fan mounting flanges.

Accessibility for service and cleaning is a very important consideration when installing an FRP tubeaxial fan. Since these fans are not available with access doors, the fan should be mounted so it is easily removable for cleaning and service. You may also provide a section of duct either side of the fan that is removable to provide access.

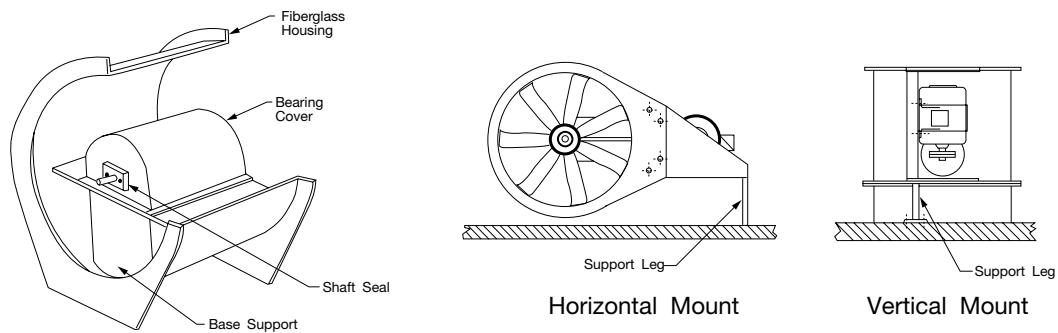

Roof Ventilators

FRP roof ventilators are made in three pieces: the fan section, the curb cap and damper section. These have been match drilled and stainless steel bolts furnished for assembly. The base can be drilled for bolting to the curb and should be caulked or sealed in an ordinary manner.

If a stack is to be added to raise the height of the discharge, it is recommended that this be placed between the fan and the wind band damper section. If this is to be exceptionally long (over 10 feet of ordinary fiberglass construction), bracing should be provided to take some of the weight of the stack section off of the ventilator fan and base assembly.

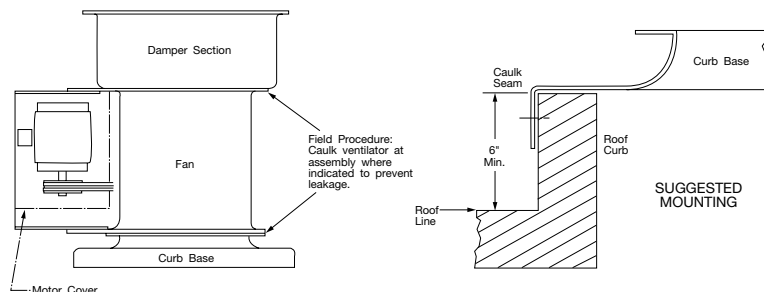

TF Tubeaxial and VTF Vaneaxial

The installation of “TF” type fiberglass fans requires the same considerations as previously outlined for the FG7 tubeaxial fans with regard to support and bracing. The “TF” tubeaxial, since it has no vane section or access door, should be mounted so that it is easily removable for cleaning. In the case of a “VTF” vaneaxial fan, the separate guide vane section may be removed which will allow access to the impeller for cleaning.

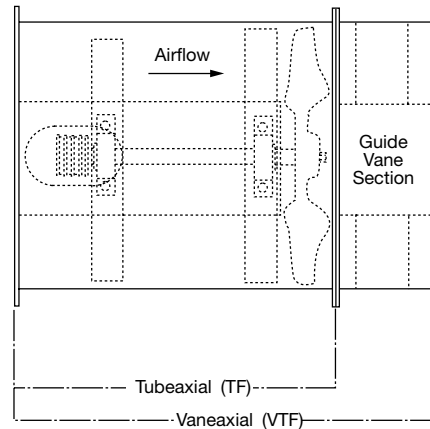

Bearing Housing

The bearings on FRP fans are enclosed in a fiberglass cover to isolate them from the airstream. Grease lines are corrosion resistant and are extended out through the belt housing to be accessible from the motor side of the fan. The bearings should be lubricated according to the operating conditions of the fan described in that section of the general installation and maintenance manual (IM-995) covering bearing lubrication. The cover enclosing the bearings and the driven sheave have been secured and sealed in place, and a shaft seal has been provided to give as complete a seal as possible. To service or replace bearings, it is necessary to first remove the impeller from the shaft and then remove the shaft seal. Remove the screws and nuts holding the cover onto the mounting surface. With a knife, cut the sealant (gray colored material) until a thin wedge (putty knife) can be used to shear the sealant material. Avoid prying on flange of bearing cover. After the sealant has been broken loose all around the joint, the cover can be easily removed exposing the bearings for service. Before replacing bearing cover, remove the hardened sealant from the flange and from the support. Lay a bead of Dow Corning 780 Building Sealant onto flange or bearing cover and complete the re-assembly.

General Maintenance

Fiberglass tubeaxial, vaneaxial fans and roof ventilators require a regular and systematic inspection of all fan parts. A general installation and maintenance manual (IM-995) has been supplied with this shipment, which includes fan and motor bearing lubrication instruction and care and replacement of V-belt drives. Regular maintenance on fiberglass fans should include the following:

1. **IMPELLER:** The impeller in an FRP axial-flow fan must be kept reasonably clean if it is to perform properly. Dirt or chemical deposits will usually build up on a impeller evenly and they present no problem to performance or operation until they become thick enough to break away in crust-like pieces. When this happens, the impeller may be thrown out of balance and the resulting vibration could be serious. When removing this crustaceous accumulation, care should be taken not to clean the impeller with sharp objects which might damage the laminated surface and reduce corrosion resistance. Should the impeller show excessive wear, it should be replaced.
2. **GUIDE VANES:** Should be cleaned at the same time as the impeller. The guide vanes are important to the performance of the fan and these particularly should be inspected.
3. **V-BELT DRIVE:** Check for proper alignment and tension. (See General Installation and Maintenance Manual IM-4050 for instructions.)
4. **FAN BEARINGS:** Lubricate the bearings as detailed on page 13 of the General Installation and Maintenance Manual. (IM-995).
5. **DAMPERS:** On roof ventilators, periodically check damper blades and remove accumulation of foreign material.
6. **SCREWS AND BOLTS:** Check for tightness throughout the assembly.



TWIN CITY FAN & BLOWER | WWW.TCF.COM

5959 Trenton Lane N | Minneapolis, MN 55442 | Phone: 763-551-7600 | Fax: 763-551-7601