

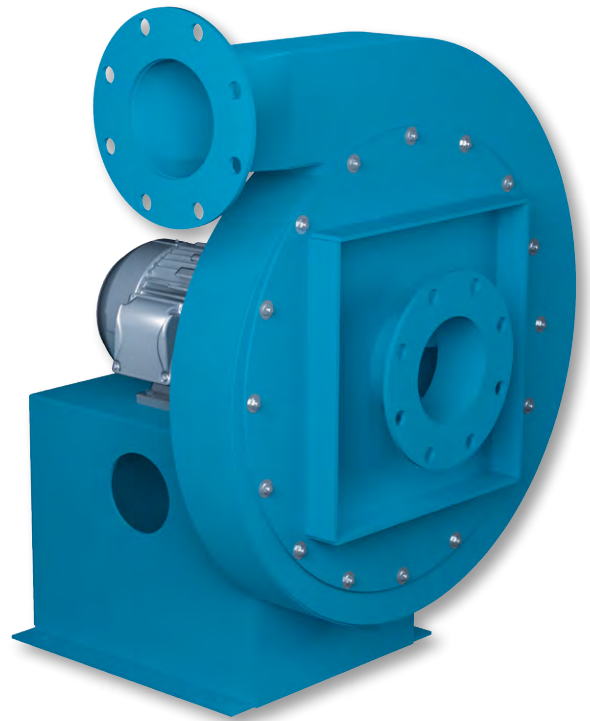

INDUSTRIAL PROCESS AND
COMMERCIAL VENTILATION SYSTEMS

PRESSURE BLOWERS

MODEL PBW



Overview

Model PBW

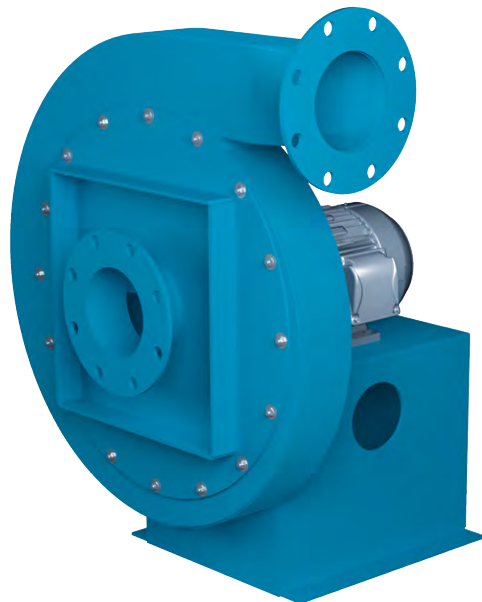

Arrangement 4
with Punched
Outlet Flange

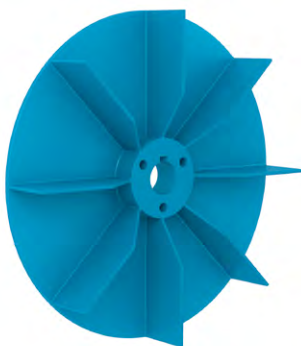

PBW Wheel

The PBW is designed for low flow and high static pressures, yet stable operation throughout its operating range. The PBW is ideal for the handling of long, stringy, or fibrous materials.

Typical Applications

- Textile fiber stripping
- Material conveying
- Product drying
- Air pollution control
- High pressure industrial-process systems
- Glass blowing
- Combustion air
- Fluid bed aeration
- Scrubber exhaust
- Gas boosting

Capabilities

- Static pressures to 60" w.g.
- Airflow capabilities to 7,700 CFM
- High temperature applications to 400°F

Housing Construction

Fans come standard with heavy-gauge, continuously welded steel housings and welded pedestals for rugged, heavy-duty, long-term service. Housings are reversible and rotatable in the field for easy retrofit and new applications. Fans come standard with a punched inlet flange, round punched flanged outlet connection and standard shaft seal.

Wheel

The PBW offers an all-welded, reversible, radial backplate wheel of constructed in Corten steel. PBW wheels are ideal for material handling applications.



For complete product performance, drawings and available accessories, download our Fan Selector program at tcf.com.

Arrangement 1 (Belt Driven)

The fan wheel on an Arrangement 1 is overhung on the shaft, i.e., mounted at the end of the shaft. The motor can be mounted in any of the four AMCA standard motor positions, W, X, Y or Z. The two fan bearings are mounted on the bearing pedestal, out of the airstream.

Arrangement 4 (Direct Drive)

The fan wheel on an Arrangement 4 is mounted directly on the motor shaft with the motor mounted on a pedestal. An Arrangement 4 offers a compact, low maintenance design, as there are no fan bearings, fan shaft or drive parts to maintain. Arrangement 4 fans are limited to 180°F.

Arrangement 8 (Direct Drive)

Arrangement 8 is a modified version of Arrangement 1 used for direct drive. The Arrangement 1 bearing pedestal is extended to accommodate the motor. A flexible coupling connects the fan and motor shaft. Consult factory for more information.

Arrangement 9 (Belt Driven)

Arrangement 9 is a belt driven fan with a motor slide base mounted on the side of the bearing pedestal. This arrangement permits the unit to ship as a complete assembly with the motor and drive mounted. Typically, the motor is mounted on the left side of the pedestal for CW rotation fans and on the right side for CCW rotation fans.



Arrangement 1



Arrangement 4



Arrangement 8



Arrangement 9

OPTIONAL CONSTRUCTION

Spark Resistant Construction

Fan applications may involve the handling of fumes or vapors. Such applications require careful consideration by the system designer to insure the safe handling of such gases. Twin City Fan & Blower offers the following classifications of spark resistant construction per AMCA Standard 99-0401-86. It is the specifier's or the user's responsibility to specify the type of spark resistant construction with full recognition of the potential hazards and the degree of protection required.

Type B - The fan shall have a nonferrous wheel and nonferrous rub ring about the opening through which the shaft passes — usually aluminum wheel and rub ring and limited to 200°F. Consult factory for availability.

Type C - The fan is constructed so that a shift of the wheel or shaft will not permit two ferrous parts of the fan to rub or strike.

High Temperature Construction

301 to 400°F - Package includes shaft cooler with guard, high temperature grease, and standard enamel paint. For Arrangement 9 fans, a motor heat shield is included.

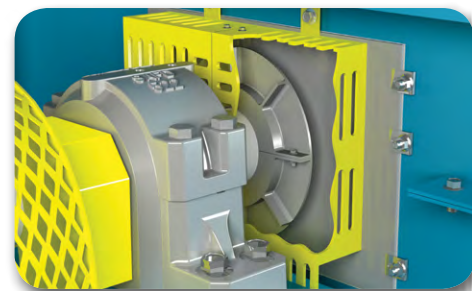

Shaft Cooler & Safety Guard

OPTIONS/ACCESSORIES

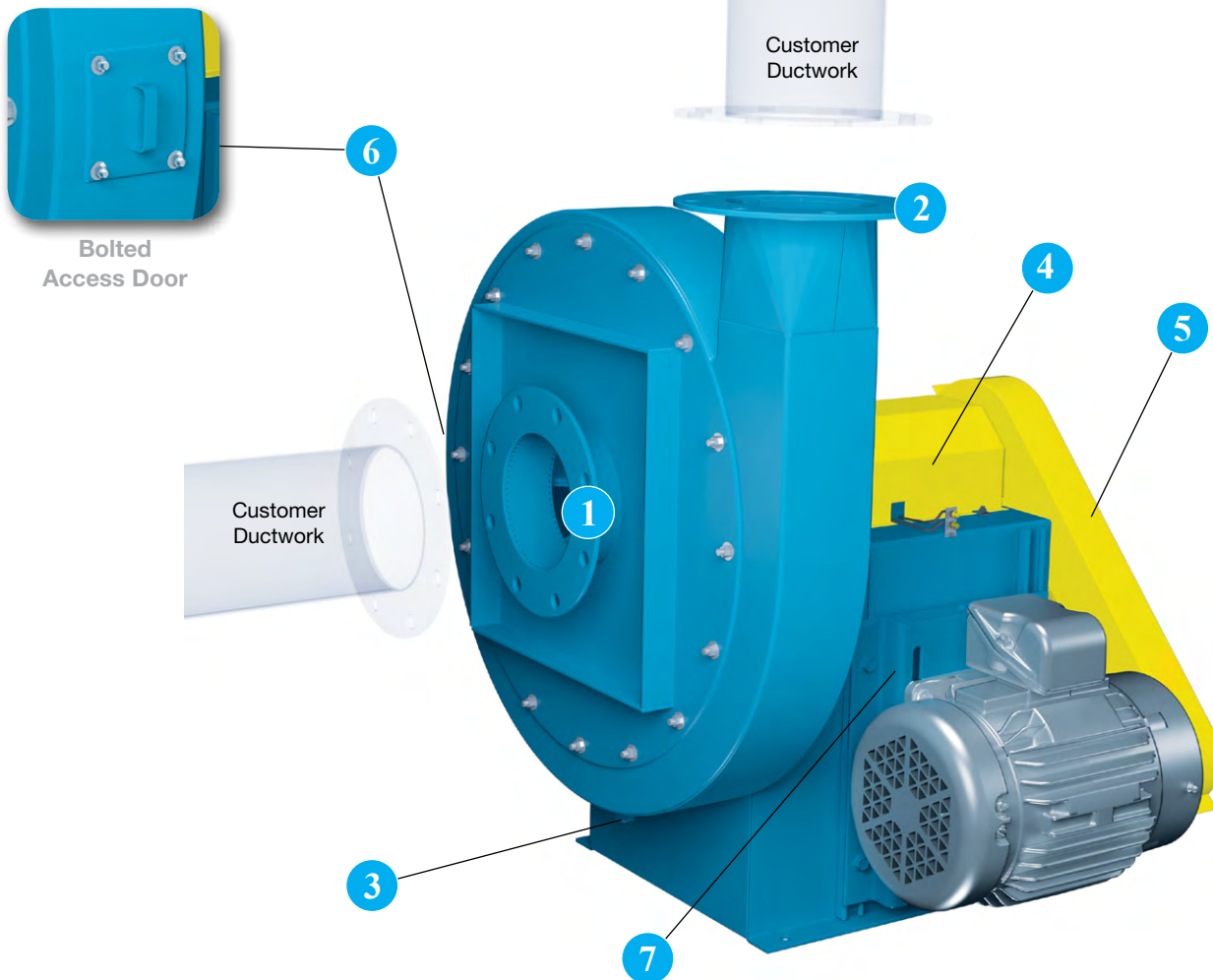

1 Flanged Inlet Punched to ANSI 125/150 hole pattern for bolted connection is standard.

2 Flanged Outlet Punched to ANSI 125/150 hole pattern for bolted connection is standard.

3 Drain Standard $\frac{3}{4}$ " NPT half coupling located at the lowest point of the housing. Available with or without plug.

4 Shaft and Bearing Guard Sheet metal guards cover shaft and bearings and come with extended lube lines to a common point outside of the guard. Painted safety yellow.

5 Belt Guard OSHA style to enclose the V-belt drive. Painted safety yellow.

6 Access Door Heavy duty bolted panel provides access for wheel inspection.

7 Motor Slide Base for positioning motors and adjust.

Other Accessories Include:

- Inlet Bell with Inlet Screen
- Belt Guard; Quick Access
- Shaft Guard (Bearings Exposed)
- Extended Lube Lines (Arr. 1, 8, & 9)
- Stainless Steel Nameplate
- Bases (Unitary, Isolation and Inertia)

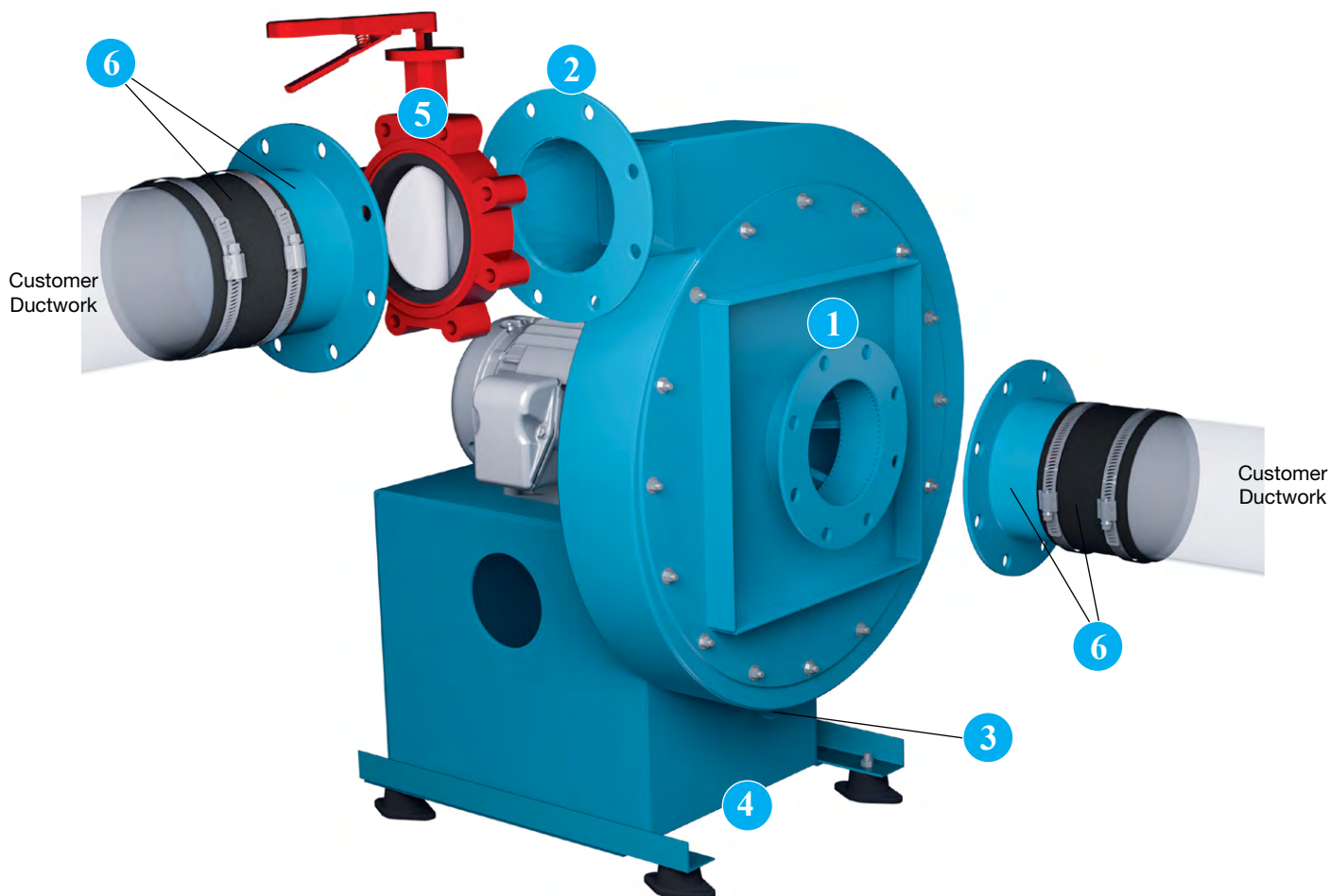

- 1 Flanged Inlet** Punched to ANSI 125/150 hole pattern for bolted connection is standard. Other patterns available upon request.
- 2 Flanged Outlet** Punched to ANSI 125/150 hole pattern for bolted connection is standard. Other patterns available upon request.
- 3 Drain** Standard $\frac{3}{4}$ " NPT half coupling located at the lowest point of the housing. Available with or without plug.
- 4 Vibration Rails w/ RIS Isolators** Designed to limit forces transmitted to the support structure of an operating fan. Constructed of structural angle, the rails extend the distance between mounting points distributing a more even load to the isolators. Rubber-in-shear type isolators and flexible connectors at inlet and outlet are often required.
- 5 Outlet Blast Gate with Handle** A wafer-type butterfly valve for mounting to outlet flange allows controlling flow to full shutoff. Available for automatic control. Maximum temperature 250°F.
- 6 Tube-Adapter with Rubber Sleeve & clamps (on inlet & outlet)** Offers flexible connection between the fan and connecting ductwork. Flexible rubber sleeve is good to 200°F operation.



Maximum RPM, Wheel Weights and WR² (moment of inertia in lb-ft²)

FAN SIZE		MAX. RPM	WEIGHT (LB)	WR ² (LB-FT ²)
HOUSING	WHEEL			
3	19	3600	38.2	9.54
	20	3600	41.2	11.4
	21	3600	44.3	13.6
	22	3600	47.6	16.1
4	19	3600	41.9	10.8
	20	3600	45.1	12.8
	21	3600	48.5	15.2
	22	3600	51.9	17.8
5	21	3600	44.3	13.6
	22	3600	47.6	16.1
	23	3600	52.1	19.3
	26	3600	69.6	32.6
6	21	3600	48.5	15.2
	22	3600	51.9	17.8
	23	3600	57.8	21.5
	26	3600	78.4	36.6

Inlet Suction Pressure Correction

If the inlet pressure is suction or negative, the static pressure required must be corrected by the inlet density ratio.

Example: Operating conditions: 70°F at sea level. System resistance at the inlet of the fan is 40".

The correction factor from the table at right is 0.902, or it can be calculated as follows:

$$(407.5 - 40") \div 407.5 = 0.902$$

Equivalent static pressure to be used for selection from the standard performance curves:

$$40" \div 0.902 = 44.36"$$

Actual air density at the inlet of the fan:

$$0.075 \text{ lb/ft}^3 \times 0.902 = 0.0676 \text{ lb/ft}^3$$

Inlet Suction Pressure Correction Factors

INLET SUCTION PRESSURE (IN. W.G.)	CORRECTION FACTOR
5	0.988
10	0.975
15	0.963
20	0.951
25	0.939
30	0.926
35	0.914
40	0.902
45	0.890
50	0.877
55	0.865

Correction Factor = (407.5 - Inlet Suction Pressure) ÷ 407.5

Shaft & Bearings

FAN SIZE		ARR. 1 & 9	
HOUSING	WHEEL DIAMETER	SHAFT DIAMETER (IN.)	BEARING TYPE
3	All	1-11/16	HDB
4	All	1-11/16	HDB
5	All	1-15/16	HDB
6	All	1-15/16	HDB

HDB: Heavy Duty Ball Bearing

Bare Fan Weights (Lbs.)

FAN SIZE		WEIGHT (LBS.)	
HOUSING	WHEEL DIAMETER	ARR. 1 & 9	ARR. 4
3	19	263	275
3	20	266	278
3	21	270	281
3	22	273	284
4	19	271	283
4	20	275	286
4	21	278	290
4	22	281	293
5	21	376	395
5	22	380	398
5	23	384	402
5	26	402	420
6	21	390	408
6	22	393	412
6	23	399	417
6	26	420	438

Note: Weights provided above are for the largest inlet/outlet size available on the housing.

Housing Thickness

FAN SIZE	HOUSING THICKNESS	
	SIDES	SCROLL
ALL	10 GA.	10 GA.

Temperature Derate

AIRSTREAM TEMP (°F)	DERATE FACTOR
70	1.00
200	1.00
300	1.00
400	1.00



Model Nomenclature

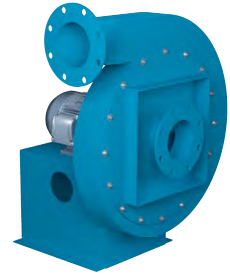
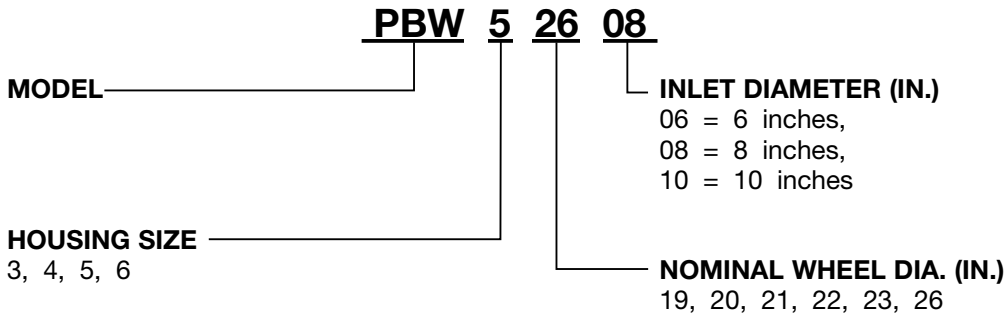

PBW 6 In. Inlet

Outlet Area: 0.196 ft²

31906, 32006, 32106, 32206

3500 RPM

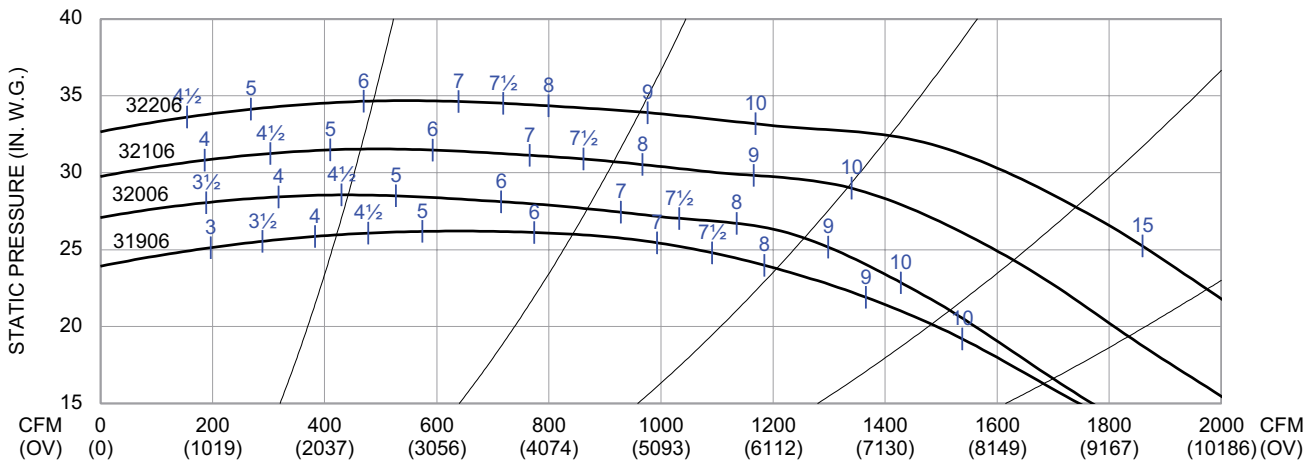

PBW 6 In. Inlet

Outlet Area: 0.196 ft²

41906, 42006, 42106, 42206

3500 RPM

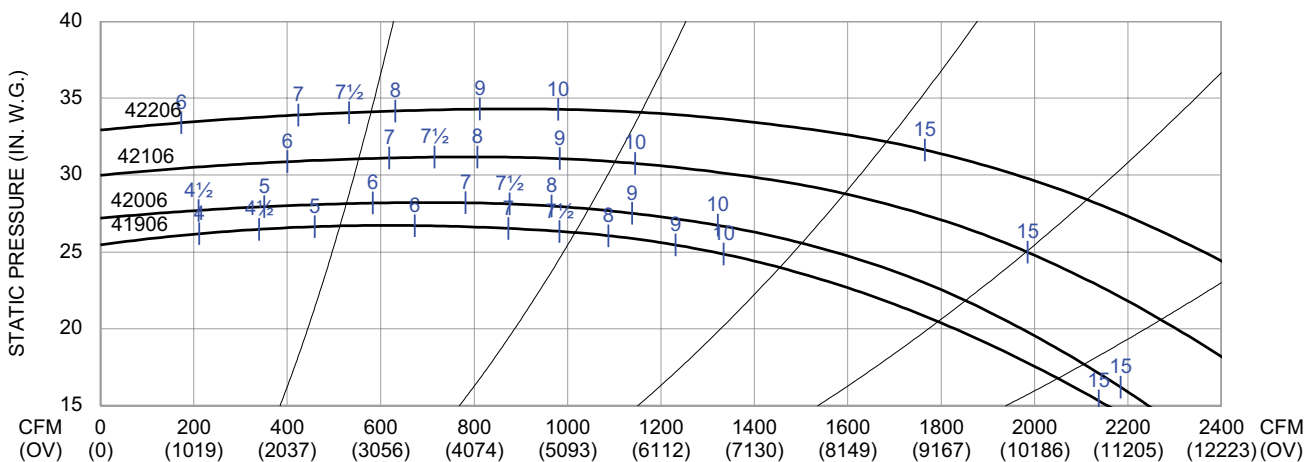

Performance shown is with a ducted outlet and a ducted inlet or inlet with venturi.

PBW 6 In. Inlet

Outlet Area: 0.349 ft²

62106, 62206, 62306, 62606

3500 RPM

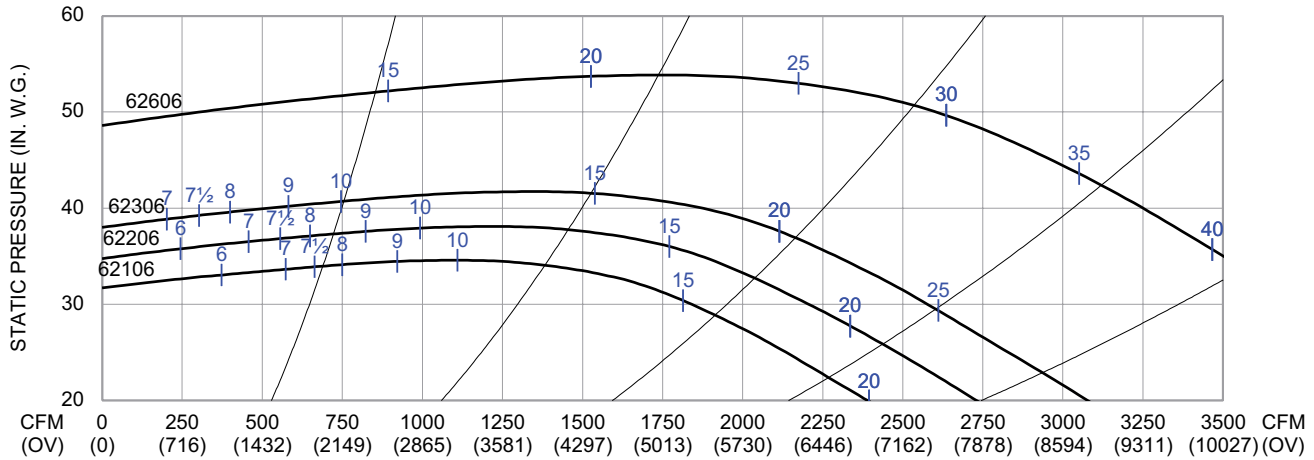

PBW 8 In. Inlet

Outlet Area: 0.196 ft²

31908, 32008, 32108, 32208

3500 RPM

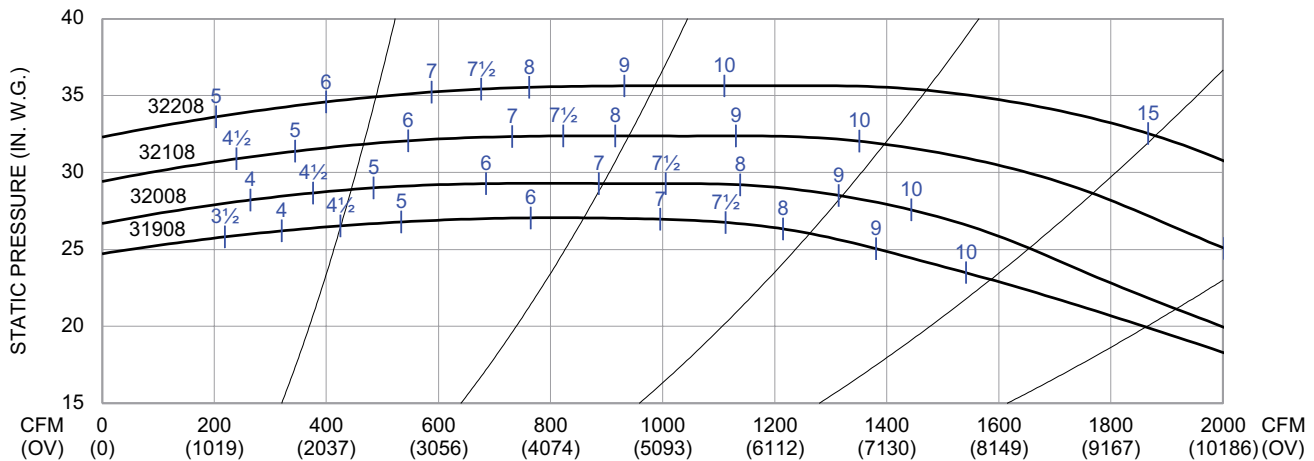

PBW 8 In. Inlet

Outlet Area: 0.196 ft²

41908, 42008, 42108, 42208

3500 RPM

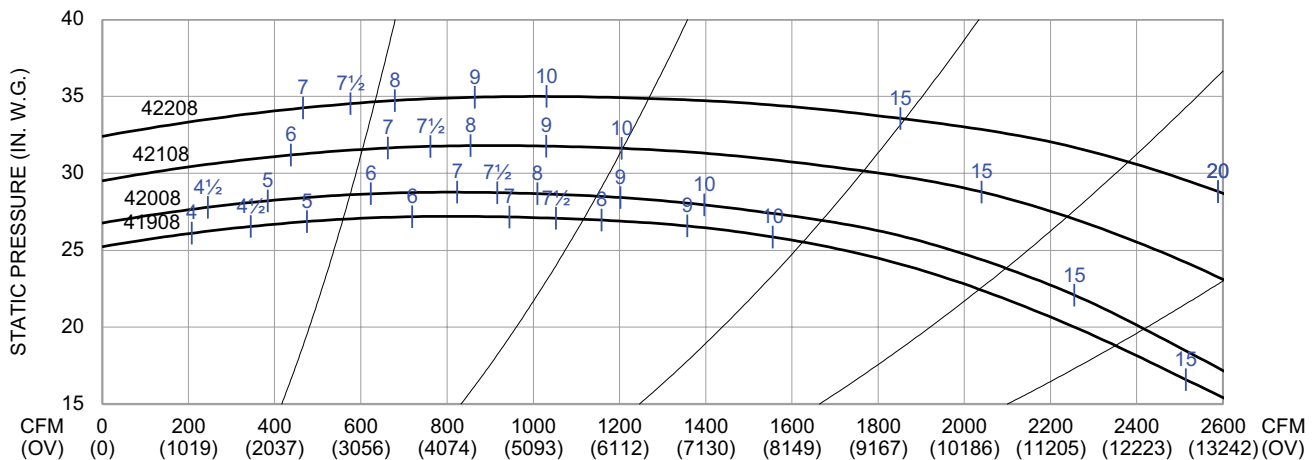

Performance shown is with a ducted outlet and a ducted inlet or inlet with venturi.

PBW 8 In. Inlet

Outlet Area: 0.196 ft²

52108, 52208, 52308, 52608

3550 RPM

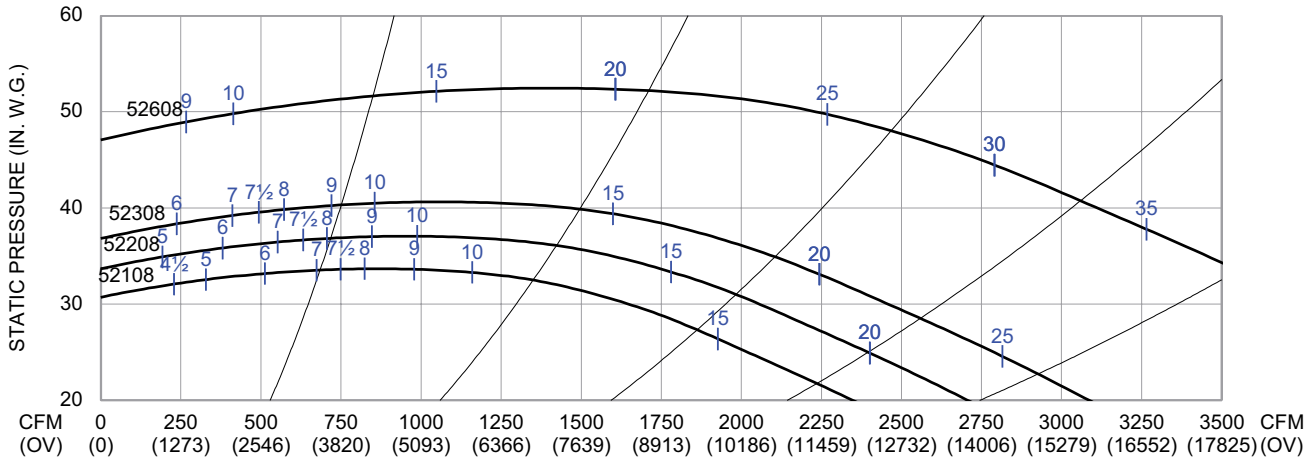

PBW 8 In. Inlet

Outlet Area: 0.349 ft²

62108, 62208, 62308, 62608

3500 RPM

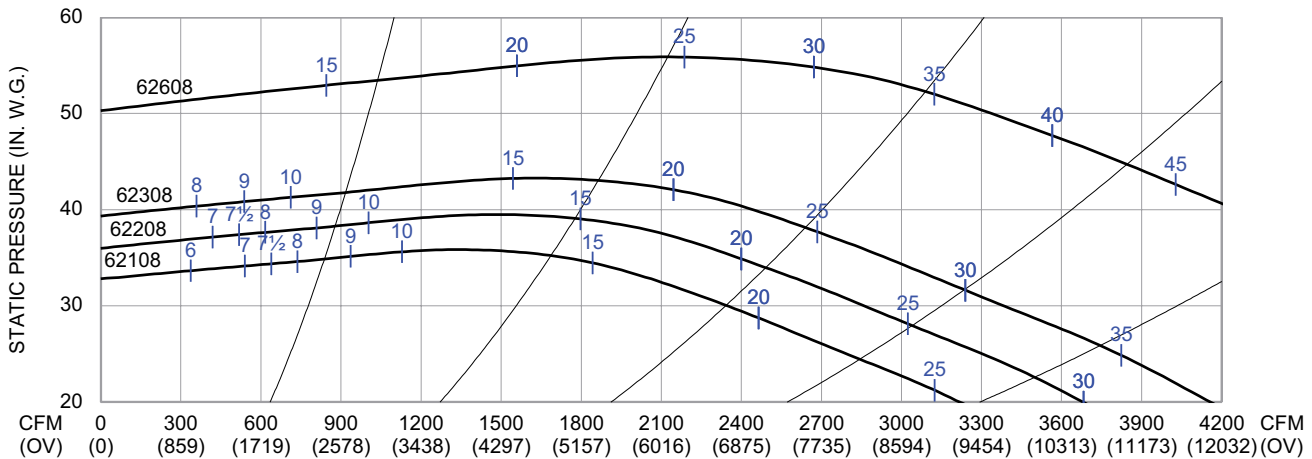

PBW 10 In. Inlet

Outlet Area: 0.196 ft²

31910, 32010, 32110, 32210

3500 RPM

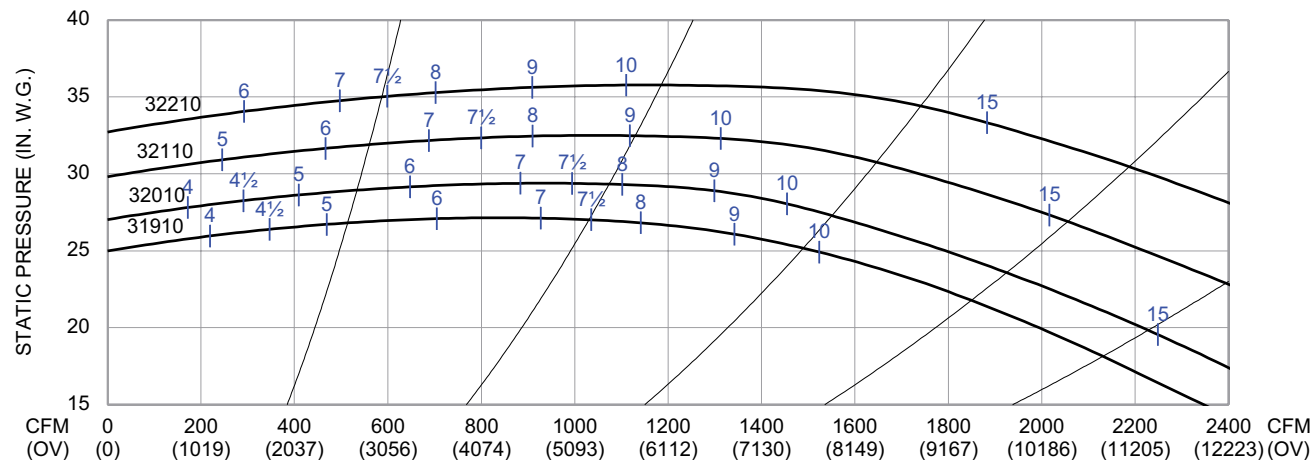

Performance shown is with a ducted outlet and a ducted inlet or inlet with venturi.

PBW 10 In. Inlet

Outlet Area: 0.196 ft²

41910, 42010, 42110, 42210

3500 RPM

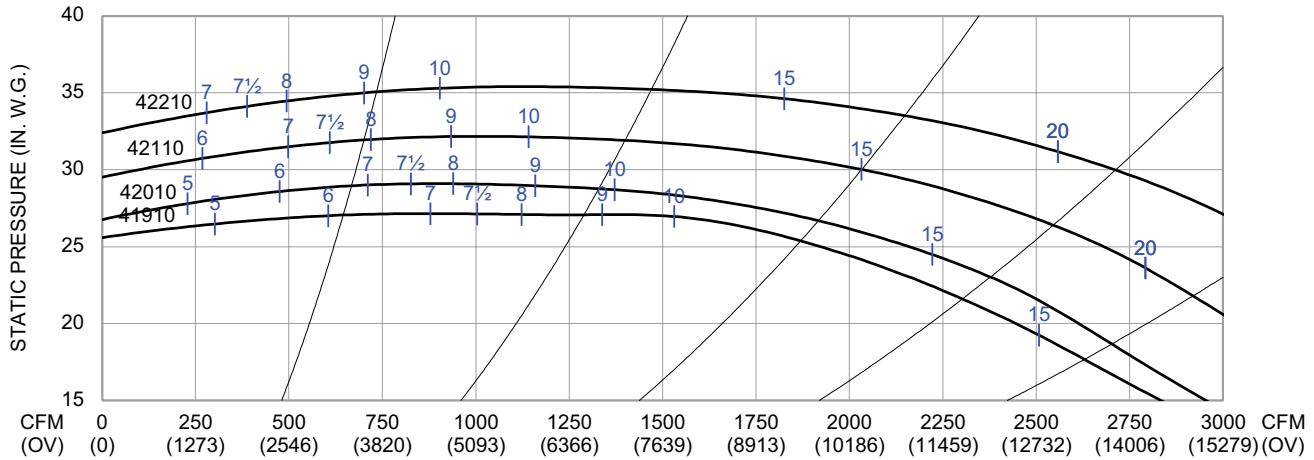

PBW 10 In. Inlet

Outlet Area: 0.196 ft²

52110, 52210, 52310, 52610

3500 RPM

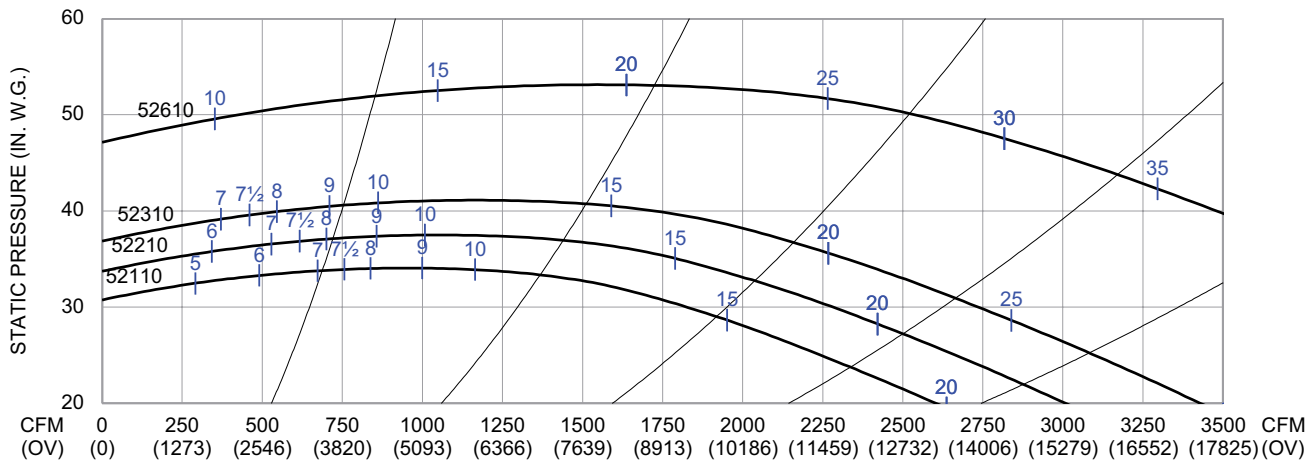

PBW 10 In. Inlet

Outlet Area: 0.349 ft²

62110, 62210, 62310, 62610

3500 RPM

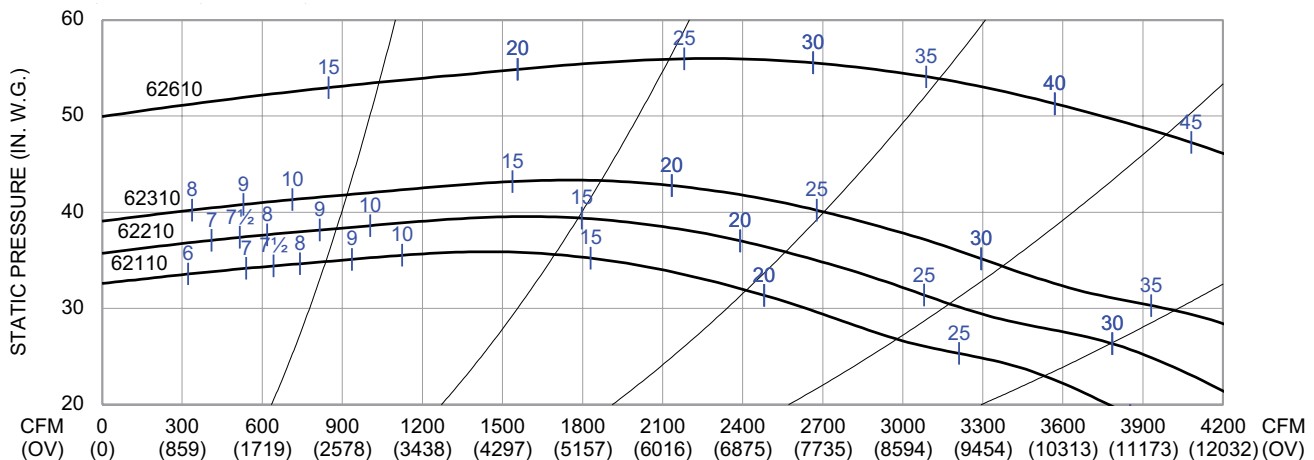

Performance shown is with a ducted outlet and a ducted inlet or inlet with venturi.

Arrangement 1

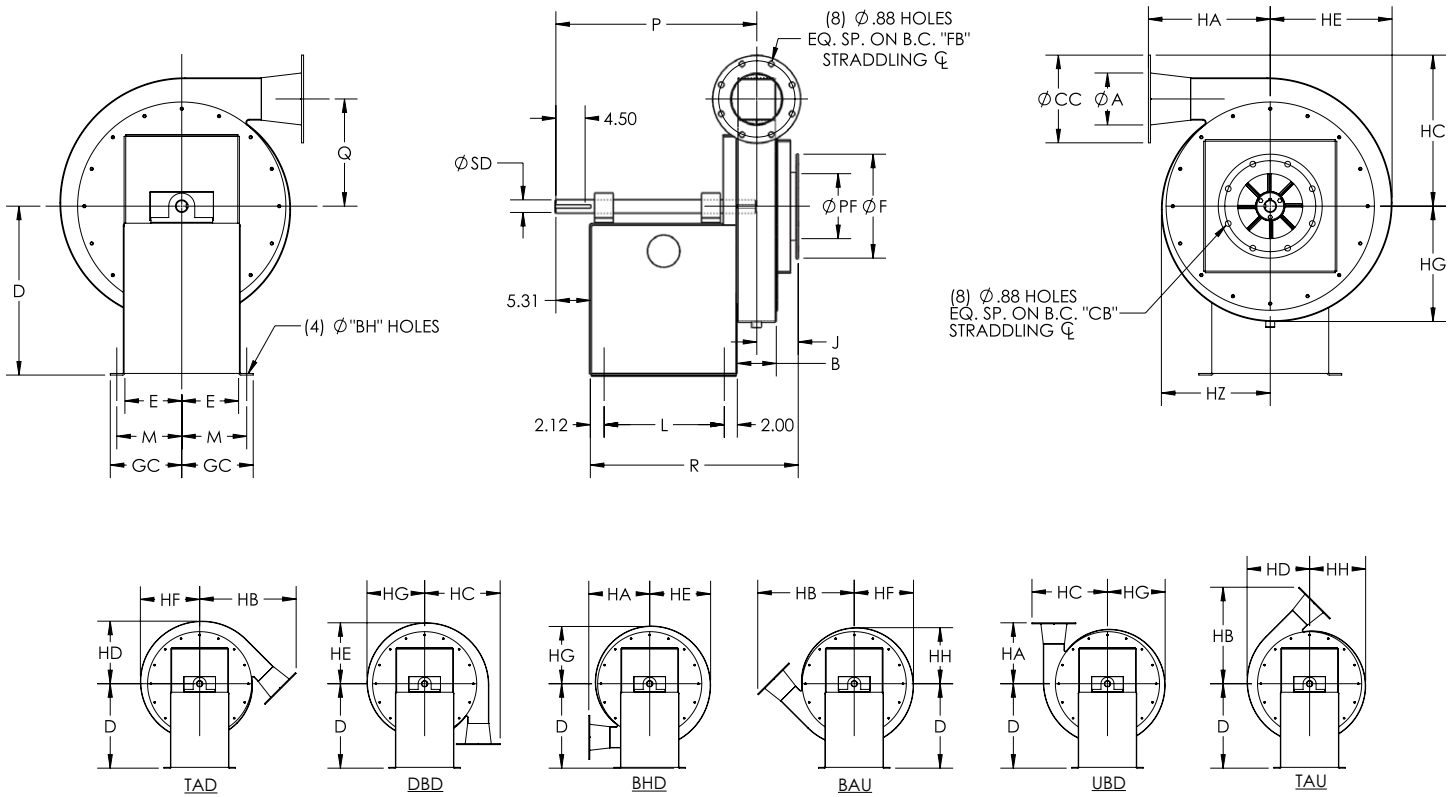

- Notes:**
1. CW rotation shown, CCW rotation similar but opposite.
 2. Optional K & B flange per BC1005899.

HOUSING SIZE	WHEEL DIAMETER (NOMINAL)	INLET DIAMETER (NOMINAL)	A	B	BH	CB	CC	D	E	F	FB	GC	HA	HB
3	19, 20, 21, & 22	6	6.00	4.50	0.56	9.50	11.00	20.00	6.81	11.00	9.50	9.00	16.00	25.63
		8				11.75				13.50				
		10				14.00				16.00				
4	19, 20, 21, & 22	6	6.00	5.50	0.56	9.50	11.00	20.00	6.81	11.00	9.50	9.00	16.00	25.63
		8				11.75				13.50				
		10				14.00				16.00				
5	21, 22, 23, & 26	6	6.00	4.75	0.69	9.50	11.00	26.00	8.75	11.00	9.50	11.00	18.75	29.70
		8				11.75				13.50				
		10				14.00				16.00				
6	21, 22, 23, & 26	6	8.00	6.00	0.69	9.50	13.50	26.00	8.75	11.00	11.75	11.00	18.75	29.70
		8				11.75				13.50				
		10				14.00				16.00				

HOUSING SIZE	HC	HD	HE	HF	HG	HH	HZ	J	L	M	P	PF	Q	R	SD	MAX MOTOR FRAME	
																EXCL. TAD & BHD	TAD & BHD
3	20.25	17.13	16.51	15.88	15.26	14.63	13.88	5.63	14.63	8.00	26.31	6.00	14.75	26.63	1.688	286T	145T
												8.00					
												10.00					
4	20.25	17.13	16.51	15.88	15.26	14.63	13.88	6.13	14.63	8.00	26.81	6.00	14.75	27.63	1.688	286T	145T
												8.00					
												10.00					
5	22.00	19.26	18.76	18.26	17.76	17.26	18.63	5.75	18.50	10.00	30.31	6.00	16.50	30.75	1.938	326T	184T
												8.00					
												10.00					
6	23.25	19.26	18.76	18.26	17.76	17.26	18.63	6.38	18.50	10.00	30.93	6.00	16.50	32.00	1.938	326T	184T
												8.00					
												10.00					

BC1006149B

DIMENSIONS ARE NOT TO BE USED FOR CONSTRUCTION. CERTIFIED DRAWINGS AVAILABLE UPON REQUEST.

Arrangement 4

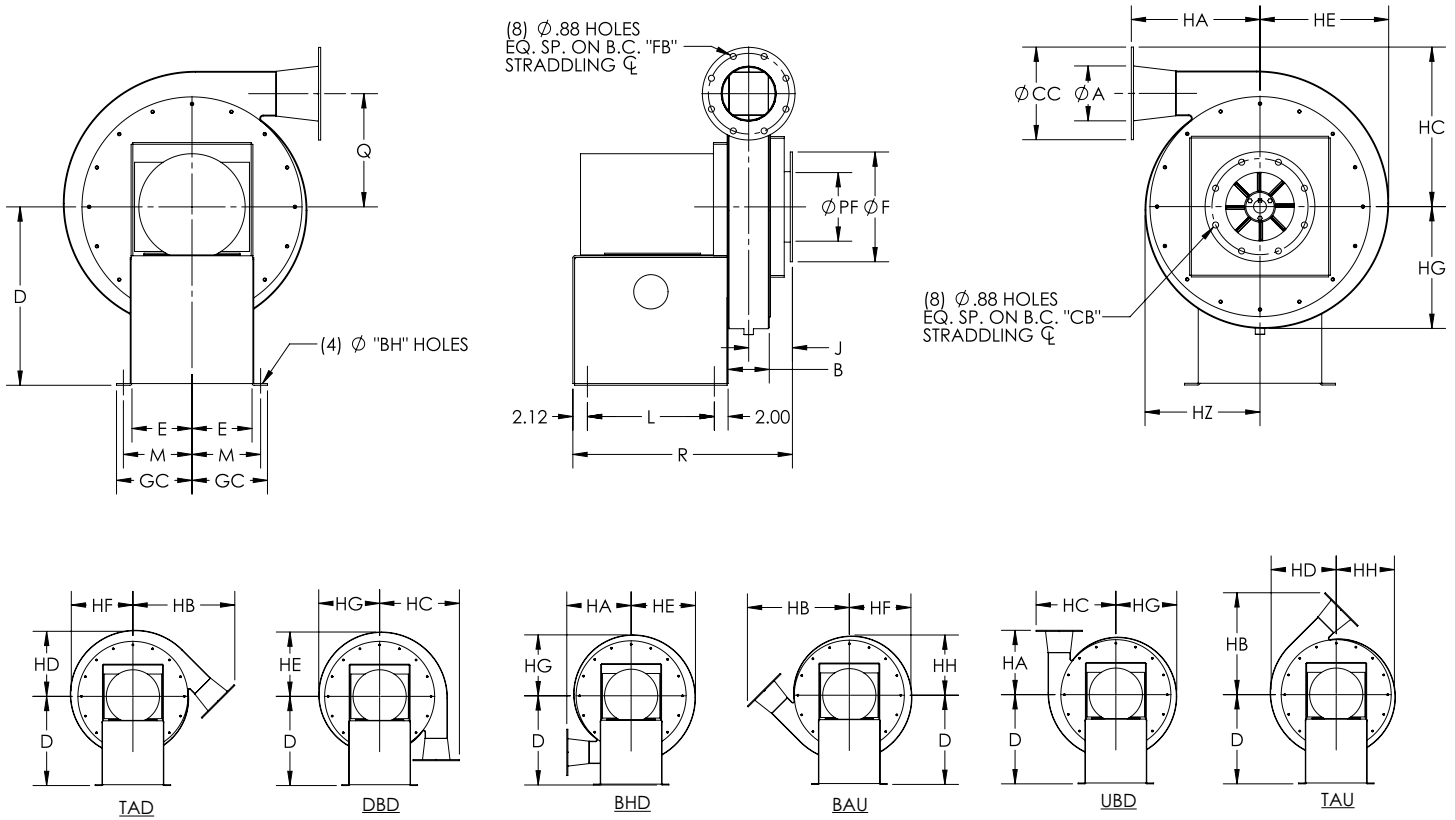

HOUSING SIZE	WHEEL DIAMETER (NOMINAL)	INLET DIAMETER (NOMINAL)	A	B	BH	CB	CC	D	E	F	FB	GC	HA	HB
3	19, 20, 21, & 22	6	6.00	4.50	0.56	9.50	11.00	20.00	6.81	11.00	9.50	9.00	16.00	25.63
		8				11.75				13.50				
		10				14.00				16.00				
4	19, 20, 21, & 22	6	6.00	5.50	0.56	9.50	11.00	20.00	6.81	11.00	9.50	9.00	16.00	25.63
		8				11.75				13.50				
		10				14.00				16.00				
5	21, 22, 23, & 26	6	6.00	4.75	0.69	9.50	11.00	26.00	8.75	11.00	9.50	11.00	18.75	29.70
		8				11.75				13.50				
		10				14.00				16.00				
6	21, 22, 23, & 26	6	8.00	6.00	0.69	9.50	13.50	26.00	8.75	11.00	11.75	11.00	18.75	29.70
		8				11.75				13.50				
		10				14.00				16.00				

HOUSING SIZE	HC	HD	HE	HF	HG	HH	HZ	J	L	M	PF	Q	R	MAX MOTOR FRAME
3	20.25	17.13	16.51	15.88	15.26	14.63	13.88	5.63	14.63	8.00	6.00	14.75	26.63	286T
											8.00			
											10.00			
4	20.25	17.13	16.51	15.88	15.26	14.63	13.88	6.13	14.63	8.00	6.00	14.75	27.63	286T
											8.00			
											10.00			
5	22.00	19.26	18.76	18.26	17.76	17.26	18.63	5.75	18.50	10.00	6.00	16.50	30.75	326T
											8.00			
											10.00			
6	23.25	19.26	18.76	18.26	17.76	17.26	18.63	6.38	18.50	10.00	6.00	16.50	32.00	326T
											8.00			
											10.00			

BC1006151B

DIMENSIONS ARE NOT TO BE USED FOR CONSTRUCTION. CERTIFIED DRAWINGS AVAILABLE UPON REQUEST.

ALTERNATIVE PRESSURE BLOWERS

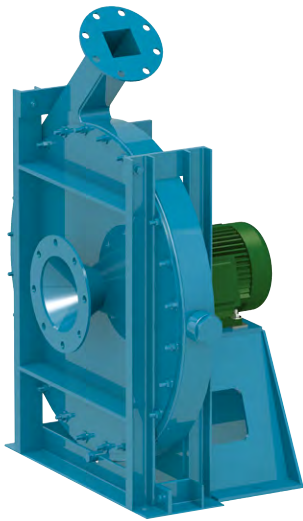

HRO Wheel

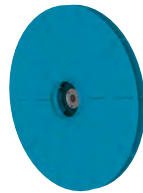

HRS Wheel

Models

HRO | HRS

Sizes

19.75" to 61.25" wheel diameters

Performance

Airflow to 10,000 CFM

Static pressures up to 120" w.g.



See Catalog 1300 for more information

Model

TBR

Sizes

10.75" to 35.19" wheel diameters

Performance

Airflow to 10,100 CFM

Static pressures to 104" w.g.



See Catalog 1200 for more information

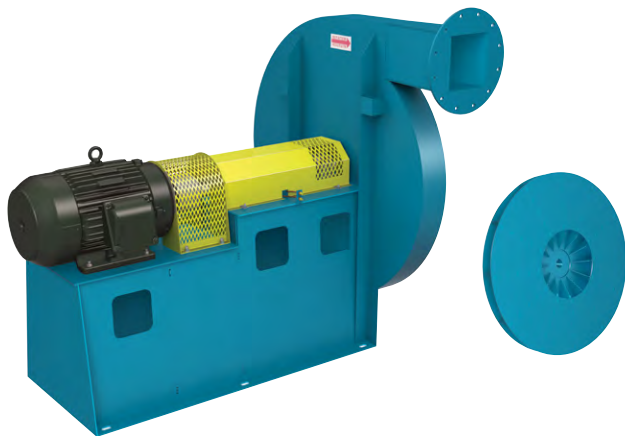

Model

TBA

Sizes

11.19" to 32.06" wheel diameters

Performance

Airflow to 28,700 CFM

Static pressures to 70" w.g.



See Catalog 1200 for more information

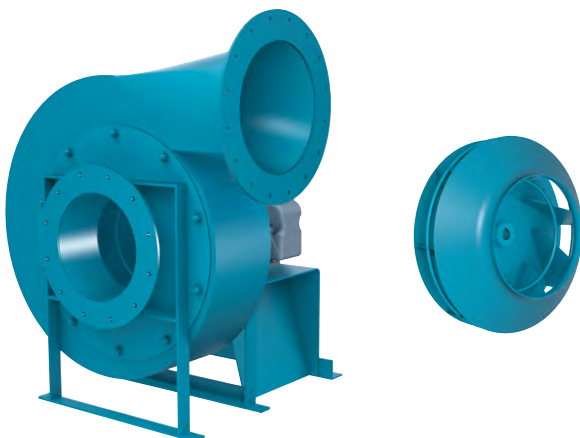

Models

MBO | MBR | MBW

Sizes

19.63" to 58.94" wheel diameters

MBO Performance

Airflow to 18,000 CFM

Static pressures over 170" w.g.

MBR Performance

Airflow to 18,000 CFM

Static pressures over 180" w.g.

MBW Performance

Airflow to 20,000 CFM

Static pressures over 160" w.g.



See Catalog 1400 for more information

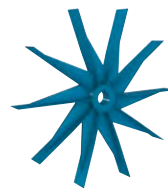
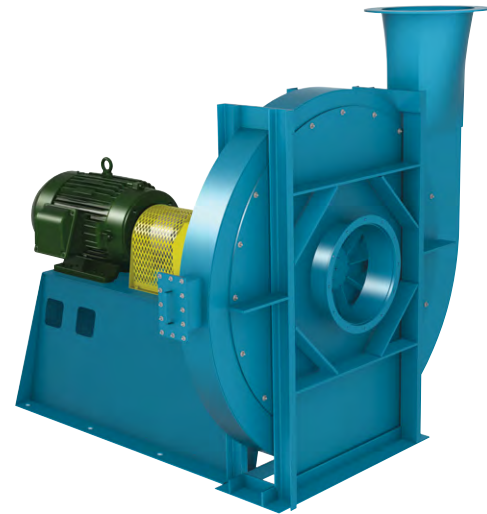

MBO Wheel



MBR Wheel

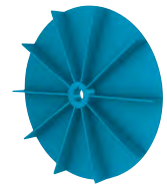

MBW Wheel

Model

BCN

Sizes

27" to 73" wheel diameters

Performance

Airflow to 75,000 CFM

Static pressures to 100" w.g.



See Catalog 1450 for more information

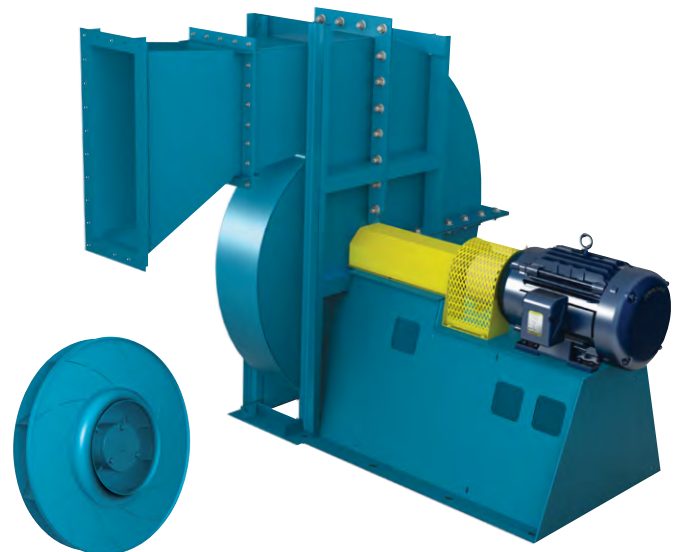



Model

PBW

Fans shall be Type PBW Pressure Blowers as manufactured by Twin City Fan & Blower, Minneapolis, Minnesota.

PERFORMANCE — Fans shall be tested in accordance with ANSI/AMCA Standard 210 (air performance) and 300 (sound performance) in an AMCA accredited laboratory.

HOUSING — Fan housings shall be constructed of continuously welded heavy gauge steel. All sizes shall be rotatable and reversible. A choice of inlet connections shall include an inlet venturi with screen, an inlet pipe assembly and a punched flange to ANSI 125/150 bolt pattern. The outlet connection shall be flanged and punched to ANSI 125/150 bolt pattern. Inlet and outlet flanges with alternate bolt patterns shall be available.

WHEEL — Wheels shall be constructed of continuously welded heavy gauge steel or from a variety of special materials. Wheels shall be statically and dynamically balanced. The complete fan assembly shall be test balanced at the operating speed prior to shipment.

SHAFT (ARR. 1, 8 & 9 ONLY) — Shafts shall be AISI 1045 hot rolled steel, accurately turned, ground, polished, and ring gauged for accuracy. Shafts shall be sized for the first critical speed of at least 1.43 times the maximum speed.

BEARINGS (ARR 1, 8 & 9 ONLY) — Bearings shall be heavy duty, grease lubricated, anti-friction ball or roller, self-aligning, pillow block type and selected for a minimum average bearing life (AFBMA L-50) in excess of 200,000 hours at the maximum fan RPM.

FINISH AND COATING — The entire fan assembly, excluding the shaft, shall be thoroughly degreased and deburred before application of a rust-preventative primer. After the fan is completely assembled, a finish coat of paint shall be applied to the entire assembly. The fan shaft shall be coated with a petroleum-based rust protectant. Aluminum components shall be unpainted.

ACCESSORIES — When specified, accessories such as inlet filters, inlet filters with hoods, inlet and outlet silencers, flexible connectors for flanged outlet and plain pipe outlets, outlet blast gates, built-in outlet dampers, shaft closure plates, shaft seals, drains, inspection ports, shaft and bearing guards, belt guards, couplings, coupling guards, unitary bases, isolation bases, inertia bases, and vibration rails shall be provided by Twin City Fan & Blower to maintain one source responsibility.

FACTORY RUN TEST — All fans prior to shipment shall be completely assembled and test run as a unit at operating speed or maximum RPM allowed for the particular construction type. Each wheel shall be statically and dynamically balanced to in accordance with ANSI/AMCA 204-96 “Balance Quality and Vibration Levels for Fans” to Fan Application Category BV-3, Balance Quality Grade G6.3. Balance readings shall be taken by electronic type equipment in the axial, vertical, and horizontal directions on each of the bearings. Records shall be maintained and a written copy shall be available upon request.

GUARANTEE — Manufacturer shall guarantee the workmanship and materials for its Pressure Blowers for at least one (1) year from startup or eighteen (18) months from shipment, whichever occurs first.

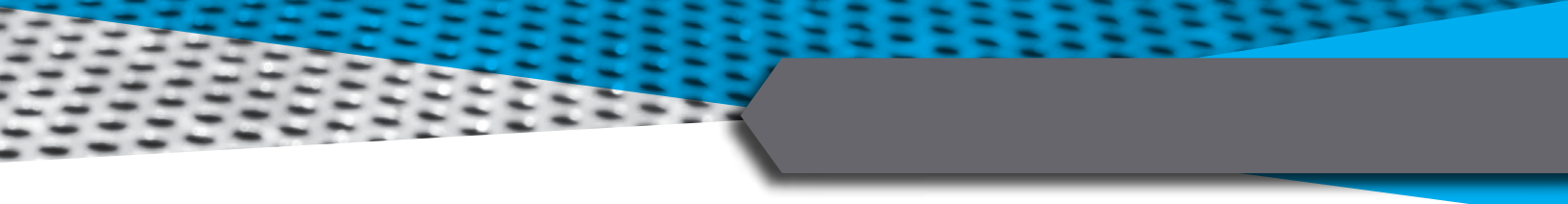

INDUSTRIAL PROCESS AND COMMERCIAL VENTILATION SYSTEMS

CENTRIFUGAL FANS | UTILITY SETS | PLENUM & PLUG FANS | INLINE CENTRIFUGAL FANS
MIXED FLOW FANS | TUBEAXIAL & VANEAXIAL FANS | PROPELLER WALL FANS | PROPELLER ROOF VENTILATORS
CENTRIFUGAL ROOF & WALL EXHAUSTERS | CEILING VENTILATORS | GRAVITY VENTILATORS | DUCT BLOWERS
RADIAL BLADED FANS | RADIAL TIP FANS | HIGH EFFICIENCY INDUSTRIAL FANS | PRESSURE BLOWERS
LABORATORY EXHAUST FANS | FILTERED SUPPLY FANS | MANCOOLERS | FIBERGLASS FANS | CUSTOM FANS



TWIN CITY FAN & BLOWER
WWW.TCF.COM

5959 TRENTON LANE N | MINNEAPOLIS, MN 55442 | PHONE: 763-551-7600 | FAX: 763-551-7601

©2018 Twin City Fan Companies, Ltd., Minneapolis, MN. All rights reserved. Catalog illustrations cover the general appearance of Twin City Fan & Blower products at the time of publication and we reserve the right to make changes in design and construction at any time without notice.