

Removing Old Cone or Vane

See Figure 2 for identification of all items referenced.

1. Shut off fan and lock out electrical power.
2. Remove belt guard and/or inlet screens.
3. Adjust motor position and remove belts and drive sheave.
4. Clean and remove rust from sections of fan shaft which extend through the fan bearings. File smooth any burrs. Remove bearing bolts and raise the shaft enough to take weight off the bearing.
5. Working through fan outlet or through access door, block under periphery of fan wheel so that fan housing supports the fan wheel.
- 6a. **For Fan With Setscrew Locking Collars** — Loosen setscrews in bearing. Using wedges or pry bars, slide bearing off end of shaft. If it is necessary to force bearing, use a brass rod to drive against inner race of bearing only.
- 6b. **For Fans With Split Type Bearing** — Remove bearing cap, bearing housing and bearing insert off end of shaft. If the bearing insert must be removed by inexperienced personnel, it is recommended that the bearing manufacturer be contacted to provide instructions for dismounting.
- 7a. **For Old Inlet Funnel Removal** — Loosen fasteners which hold inlet cone and bearing support frame to the housing side. Remove old inlet cone and bearing support frame.
- 7b. **For Pre-1981 Style Inlet Vane Removal** — Remove hardware from old vane which attaches it to the housing side. Remove control arm (or drive link). Loosen fasteners which hold inlet cone and bearing support frame to fan housing side, then remove old inlet vane and bearing support frame.
- 7c. **For Post-1981 Style Inlet Vane Removal** — Remove nut (item 16) and pull connecting arm out of the way. Loosen fasteners which hold inlet vane and bearing support frame to the housing side, then remove the inlet vane and bearing support frame.
8. Repeat steps 4, 6, and 7 on other side of the fan.

Assembling Nested Inlet Vane

1. Using Figure 2 as a guide, assemble items 4 through 16 to the inlet vane. Measure threaded linkage rod (item 6) to fit.
2. Center inlet vane in location of old vane or cone, and rotate until inlet vane control ring is approximately in the same position as shown in Figure 3. If old control linkage is being reused, locate control ring clip so that connecting link can be reattached. Be sure that when vane is partially closed the entering air will be spun in the direction of wheel rotation.
3. For installation of new quadrant, using the dimensions in Figure 4, position quadrant (item 2 or 2A) to the housing side. Weld quadrant to the housing frame (or housing side).
4. Drill a hole in the fan housing side to match the diameter of control rod (item 3).
5. Reassemble bearing support frame and bolt it to fan housing as shown in Figure 1.
6. Reassemble the bearing.
7. Repeat steps 1, 2, 4, 5, and 6 on the other side of the fan.
8. Remove blocking under the fan wheel and check to be sure the wheel turns freely. Adjust bearing position or inlet vane position as required. Tighten bearing fasteners.
9. Assemble the remaining parts of control system according to Figure 2. Adjust position of connecting links as required to enable both vanes to open/close smoothly and uniformly. Threaded linkage rods (item 6) may have to be cut to required length.
10. Welded threaded linkage rod housing to hex nuts (item 14). Spot weld the control rod to vane handle and control linkage bar.
11. Reinstall the drive, guards, inlet screens, access door hardware, etc.

Figure 1. BC, BAF DWDI Fan With Nested Inlet Vanes

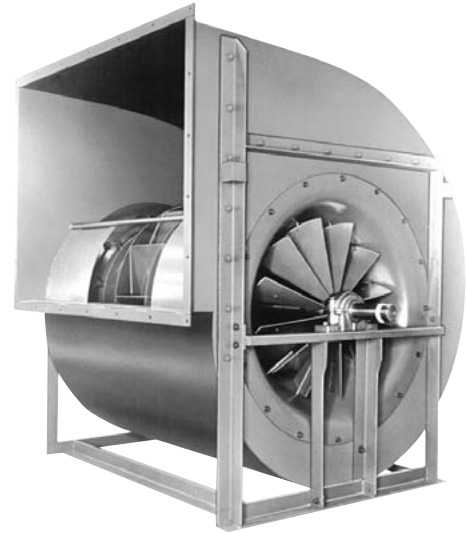
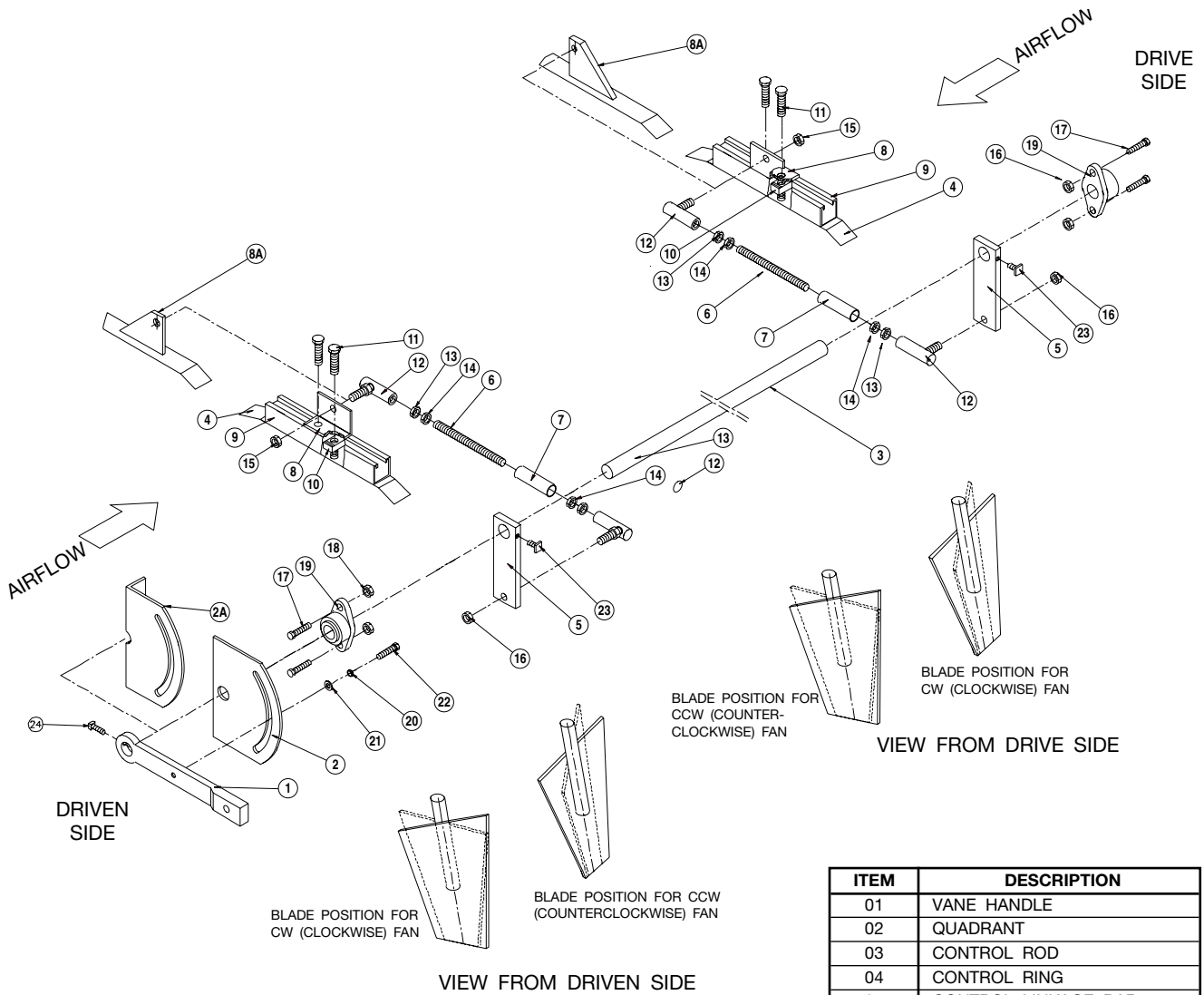

Figure 2. Nested Inlet Vane Control System for DWDI BC, BAF Fans



NOTES:

1. Items 8, 9, 10, and 11 are used for fan sizes 245 thru 890.
2. Item 8A is used for fan sizes 165 thru 222.
3. Item 2 is used for nonrotatable housing design and is to be welded to the fan housing frame.
4. Item 2A is used for rotatable housing design and is to be welded on the fan housing.
5. Bearings are to be mounted on the outside of the fan housing.
6. Items 7 and 14 are used for fan sizes 600 and larger.
7. Measure threaded linkage rod length to fit.

ITEM	DESCRIPTION
01	VANE HANDLE
02	QUADRANT
03	CONTROL ROD
04	CONTROL RING
05	CONTROL LINKAGE BAR
06	THREADED LINKAGE ROD
07	THREADED LINKAGE ROD HSG.
08	CONTROL RING CLIP
09	UNISTRUT
10	UNISTRUT CLAMPING NUT
11	HEX NUT
12	BALL JOINT
13	HEX NUT
14	HEX NUT
15	HEX NUT
16	HEX NUT
17	HEX BOLT
18	NEX NUT
19	FLANGE BEARING
20	SPRING LOCK WASHER
21	FLAT WASHER
22	HEX HEAD SCREW
23	SQUARE HEAD SETSCREW
24	SQUARE HEAD SETSCREW

Figure 3. Control Ring Position

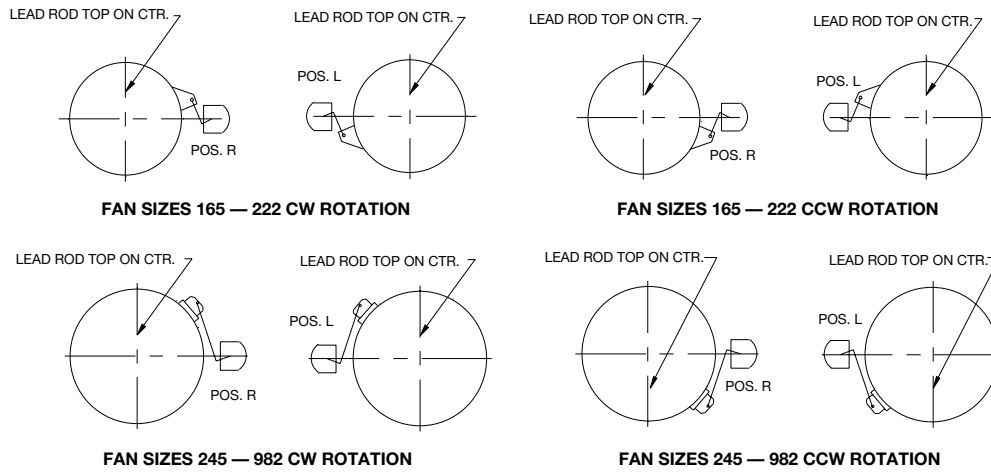

- NOTES:**
- For POS. R:
CW fan handle down is open.
CCW fan handle down is closed.
 - For POS. L:
CW fan handle down is closed.
CCW fan handle down is open.
 - Handle location on inlet side of fan.
 - Reference of AC-13460.

Figure 4. Nested Inlet Vane Handle Location For Non-rotatable Fans

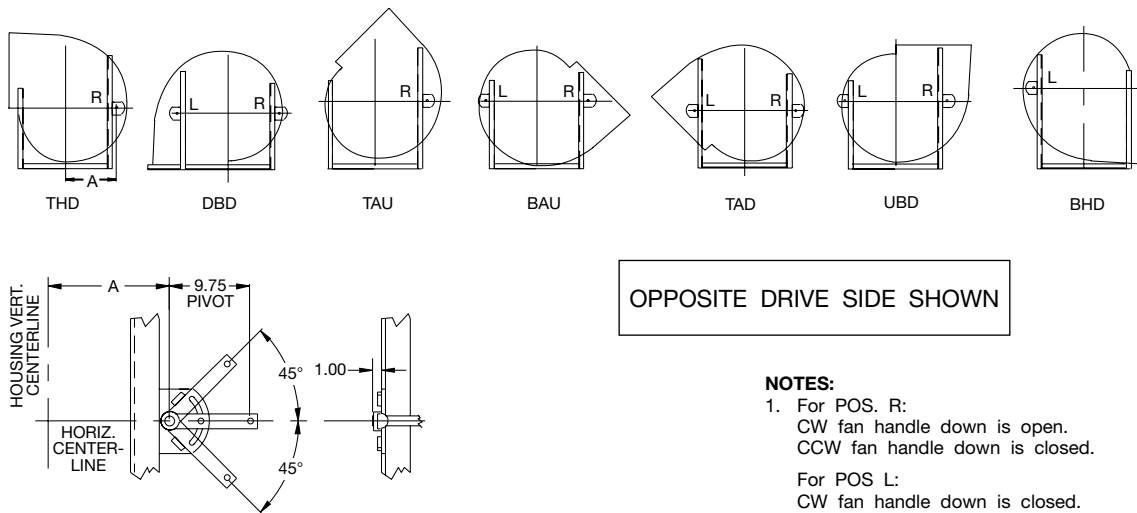

- NOTES:**
- For POS. R:
CW fan handle down is open.
CCW fan handle down is closed.
 - For POS. L:
CW fan handle down is closed.
CCW fan handle down is open.
 - All dimensions are references to AC-13459.

FAN SIZE	NESTED INLET VANE HANDLE LOCATION							DIMENSION "A"							
	DBD	TAD	THD	TAU	UBD	BAU	BHD	SWSI				DWDI			
								CL I	CL II	CL III BCS 17	CL IV BCS 22,26	CL I	CL II	CL III	
165	L	L	R	R	R	R	L	12.88	12.88	12.88	12.88	12.88	12.88	12.88	12.88
182	L	L	R	R	R	R	L	13.75	13.75	14.25	14.75	13.75	13.75	14.25	14.25
200	L	L	R	R	R	R	L	14.75	14.75	15.25	15.75	14.75	14.75	15.25	15.25
222	L	L	R	R	R	R	L	16.38	16.38	16.88	16.88	16.38	16.38	16.88	16.88
245	L	R	R	R	R	R	L	17.50	17.50	18.00	18.00	17.50	17.50	18.00	18.00
270	L	R	R	R	R	R	L	18.75	18.75	19.25	19.75	18.75	18.75	19.50	19.50
300	L	R	R	R	R	R	L	21.25	21.25	21.75	21.75	21.25	21.25	22.00	22.00
330	R	R	R	R	R	R	L	22.75	22.75	23.25	23.50	22.75	23.00	23.50	23.50
365	R	R	R	R	R	L	L	24.75	24.75	25.50	25.50	24.75	25.00	25.50	25.50
402	R	R	R	R	R	L	L	27.00	27.00	27.25	27.25	27.00	27.25	27.50	27.50
445	R	R	R	R	R	L	L	29.00	29.00	29.25	29.75	29.25	29.25	29.50	29.50
490	R	R	R	R	R	L	L	31.50	31.75	31.75	32.50	31.75	31.75	32.00	32.00
542	R	R	R	R	L	L	L	34.25	34.50	34.50	35.25	34.50	34.75	34.75	34.75
600	R	R	R	R	R	L	L	37.50	37.50	38.25	38.25	37.50	37.75	38.50	38.50
660	R	R	R	R	R	L	L	41.00	41.00	41.25	41.75	41.25	41.25	41.50	41.50
730	R	R	R	R	L	L	L	45.00	45.25	45.50	46.00	45.25	45.50	45.75	45.75
807	R	R	R	R	L	L	L	48.75	49.00	49.75	50.00	49.00	49.25	50.00	50.00
890	R	R	R	R	L	L	L	54.50	54.50	55.25	55.50	54.75	55.00	55.50	55.50
982	R	R	R	R	L	L	L	62.25	62.50	58.50	58.75	62.50	62.75	58.75	58.75

Figure 5. Nested Inlet Vane Handle Location For Rotatable Fans

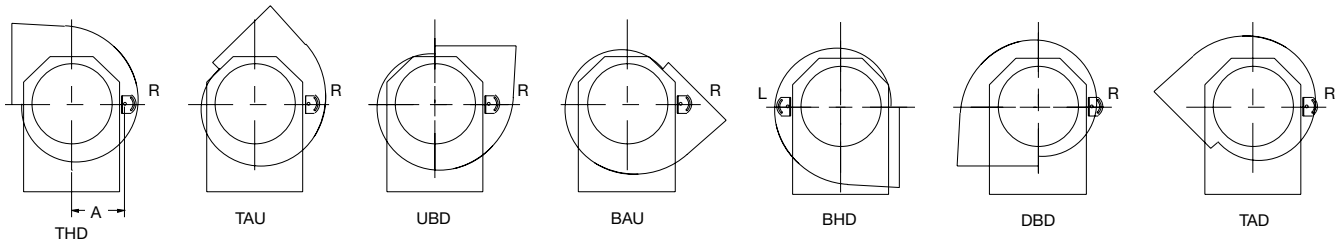

CW ROTATION INLET SIDE SHOWN
IF DWDI, OPPOSITE DRIVE SIDE.

- NOTES:**
- For POS. R:
CW fan handle down is open.
CCW fan handle down is closed.
For POS L:
CW fan handle down is closed.
CCW fan handle down is open.
 - For split housing, consult factory.

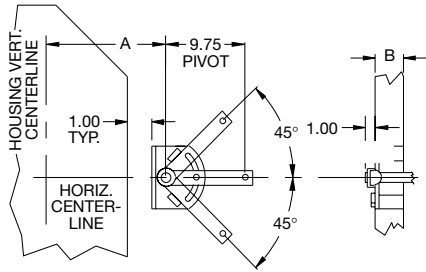

FAN SIZE	165	182	200	222	245	270	300	330	365
A	11.25	12.25	13.50	14.62	15.88	17.50	19.06	20.44	22.88
B	1.69	1.69	1.69	21.9	2.19	2.19	2.69	2.69	2.69



TWIN CITY FAN & BLOWER | WWW.TCF.COM

5959 Trenton Lane N | Minneapolis, MN 55442 | Phone: 763-551-7600 | Fax: 763-551-7601