

Throughout this manual, there are a number of HAZARD WARNINGS that must be read and adhered to in order to prevent possible personal injury and/or damage to equipment. Two signal words "WARNING" and "CAUTION" are used to indicate the severity of a hazard and are preceded by the safety alert symbol.

 **WARNING**

Used when serious injury or death MAY result from misuse or failure to follow specific instructions.

 **CAUTION**

Used when minor or moderate injury or product / equipment damage MAY result from misuse or failure to follow specific instructions.

NOTICE

Indicates information considered important, but not hazard-related.

It is the responsibility of all personnel involved in installation, operation and maintenance to fully understand the  Warning and  Caution procedures by which hazards are to be avoided.

Electronically Commutated Motors

Electronic commutation (EC) is the latest motor technology to be used in direct drive fans. Also known in the industry as Permanent Magnet, Brush Free or Brushless DC, the EC motors utilize an electronic circuitboard to control the functionality of the motor. The motor operates off of

115V or 208/230V AC single phase power or 208/230V or 460 three phase power, which is converted to DC power within the motor's circuitry. The result is a highly efficient motor with an expanded speed control range and a variety of speed control options to choose from.

General Installation

 **CAUTION**

Sheet metal parts, screws, clips and similar items inherently have sharp edges, and it is necessary that the installer and service personnel exercise caution.

 **CAUTION**

Surface temperatures of motor may reach temperatures which can cause discomfort or injury to personnel accidentally coming into contact with hot surfaces. When installing, protection should be provided by the user to protect against accidental contact with hot surfaces. Failure to observe this precaution could result in bodily injury.

 **CAUTION**

This equipment contains voltages that may be as high as 1000 volts! Electrical shock can cause serious or fatal injury. Do not touch any circuit board, power device or electrical connection before you first ensure that the power has been disconnected. Always disconnect, lock and tag power source before installing or servicing. Failure to disconnect power source can result in fire, shock or serious injury.

 **WARNING**

Pacemaker danger – Magnetic or electromagnetic fields in the vicinity of current carrying conductors and permanent magnetic motors can result in a serious health hazard to implants and hearing aids. To avoid risk, stay away from the area surrounding a permanent magnet motor.

The installation of this equipment shall be in accordance with the regulations of authorities having jurisdiction and all applicable codes.

This equipment is to be installed by an experienced installation company and fully trained personnel.

Verify that the wheel rotation is correct. It should be CW when viewed from the shaft end (CCW from opposite shaft end).

Refer to IM-4050, IM-4205 or IM-4800 for detailed installation instructions on the fans that utilize EC motors.

Do not operate the fan beyond the maximum cataloged RPM. The current should be verified any time the RPM is adjusted to ensure it is below the nameplate amperage value.

Electrical Connection

1. Connect supply wiring to the disconnect switch (non-fused standard).
2. The motor is factory set at the voltage marked on the fan nameplate. Check the line voltage with the nameplate voltage.
3. The main power wiring should be sized for the ampacity shown on the dataplate. Size wires in accordance with the ampacity tables in Article 310 of the National Electrical Code. If long wires are required, it may be necessary to increase wire size to prevent excessive voltage drop. Wires should be sized for a maximum of 3% voltage drop.

CAUTION

Use copper conductors only.

CAUTION

Protect wiring from sharp edges. Leave some slack in the line to prevent damage. Do not allow the power or speed control cables to kink or come in contact with oil, grease, hot surfaces or chemicals. If damaged, discontinue use immediately and have cord replaced. Use proper strain relief.

4. Disconnect switches are not fused. The power leads must be protected at the point of distribution in accordance with the fan dataplate.
5. All units must be electrically grounded in accordance with local codes or, in the absence of local codes, with the latest edition of the National Electrical Code (ANSI/NFPA 70). A ground lug is provided as standard in the unit terminal box. Size grounding conductor in accordance with Table 250-95 of the National Electrical Code. **DO NOT** use the ground lug for connecting a neutral conductor.
6. Supply voltage to the power ventilator should not vary by more than 10% of the value indicated on the unit dataplate. Phase unbalance must not exceed 2%.

Speed Control Options: ECODP & ECTENV Motors

This section covers the motors listed in the following chart:

TCF Part Number	Manufacturer's Part Number	HP	Voltage/Phase
67001001	F2216B4044	1/4	115/1
67001003	F2232B4045	1/2	115/1
67001004	F2240B4046	3/4	115/1
67001005	F2256B4047	1	115/1
67001105	F2280B43385	1	115/1
67002101	F2216A4723	1/4	208-230/1

Three speed control options are available for the Twin City Fan EC motor. Coming standard with the motor is both a motor mounted dial, for speed adjustment at the fan (first option), and a 0-10V DC control lead. The 0-10V DC control lead can be used with a remote speed control, either field supplied (second option) or supplied by TCF (third option).

1. **Motor Mounted Dial (Standard Feature)** – A potentiometer is mounted to the motor housing offering full speed control range. Speed adjustment is made with a small flat head screwdriver. With this option, the motor's 0-10V DC control leads are terminated in a standard 2x4 junction box from the factory and can remain there if not required by the end user.

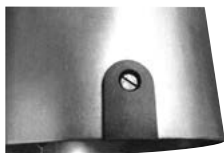

2. **0-10V DC Lead (Standard Feature)** – A 36" long control lead is prewired from the motor which accepts a 0-10V DC signal and can be wired into building control systems or field supplied controls. With this option, the control leads are terminated in a standard 2x4 junction box from the factory.

Field supplied controllers should be provided and installed by others and send the motor a 0-10V DC signal. A 24V AC or DC source is also required to power the controls in the motor. Note that the motor mounted dial acts as a speed reference for this option. In order to have the full speed control range available for a given fan/motor combination, the motor mounted dial must be turned all the way in the CW direction or to the maximum RPM allowable for the fan/motor combination (look for labels on fan). The motor operates off of a 2-10V DC signal while the motor will be off when a 0-1.9V DC signal is present. **It is the responsibility of the installer/controls engineer to ensure that any field supplied controls are compatible and functional with this motor technology. TCF is not responsible for field supplied or customer designed fan or motor controls.**



CAUTION

Always disconnect power before inspection or maintenance. Although motor may be off and not running when a 0-1.9V DC signal is present, high voltage will still be present at the motor.

3. Remote Mounted Dial (Optional Feature) – A wall mounted dial allows the fan to be controlled from within the building by sending the motor a 0-10V DC option. This option includes a 115V or 230V (depending upon the motor voltage selected) to 24V AC transformer mounted in the NEMA electrical enclosure. On models DCRD, DCRU/R, DCRW/R and DCLH/P the junction box for the transformer will be located within the fan motor enclosure. On models DSI and TCPE, the junction box for the transformer will be located on the exterior of the fan.



With this option a 3 wire control cable must be field supplied and wired from the 24V AC transformer box to the remote location of the controller. In addition, a standard 2x4 single gang electrical junction box (by others) is required to mount the controller. The maximum distance from the remote mounted controller to the motor is 100 feet. Distances greater than this could cause a loss of the signal to the motor and result in unstable motor performance.

On the back of the remote mounted dial there is a small switch which will allow the user to change the output of the remote mounted dial. The settings of the switch are 0-10V or 2-10V. A label on the rear of the controller's printed circuitboard describes the settings. The motor will run regardless of which setting the dial is at, but because the motor operates off of a 2-10V DC signal, it will be off when a 0-1.9V DC signal is present. If the user requires the remote mounted dial to turn off the motor, the dial should be set at 0-10V DC.

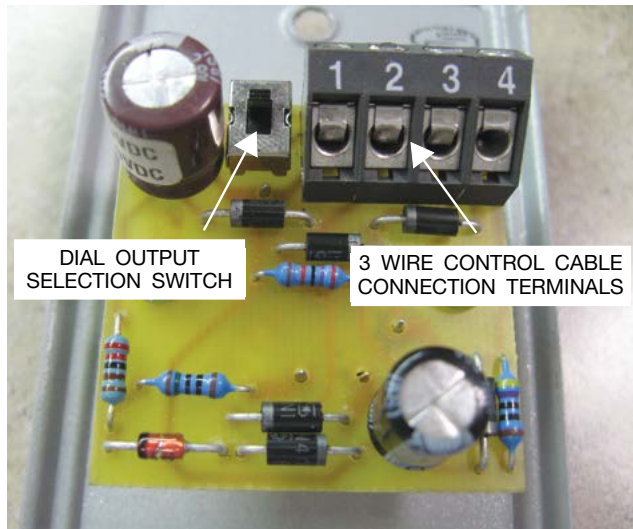

With the field supplied 3 wire control cable connections from the transformer box to the remote mounted dial must be made as follows:

Connection in Transformer Box	Description	Terminal on Back of Dial
Yellow/White	Common	1
Blue/Black	24V AC	2
Red	0-10V DC	3

The user should verify that the dial is properly working by adjusting the dial and checking that the motor speed changes accordingly. The voltage at the dial should also be verified. 24V AC should be present across terminal 1 and 2. Terminals 1 and 3 should have a DC voltage in the range of 0-10V DC which should vary as the dial is adjusted.

Note that the motor mounted dial acts as a speed reference for this option. In order to have the full speed control range available for a given fan/motor combination, the motor mounted dial must be turned all the way in the CW direction or to the maximum RPM available.

Figure 1 and Figure 2 (pages 4 and 5) are detailed wiring diagrams for the Remote Mounted Dial option.

⚠ CAUTION

Always disconnect power before inspection or maintenance. Although motor may be off and not running when a 0-1.9V DC signal is present, high voltage will still be present at the motor.

Maintenance

Keep motor dry and free of dirt, dust and debris.

Troubleshooting

Remote Dial does not vary the motor speed

- Verify that correct connections are made (refer to page 2).
- Make sure that the connections are solid.
- Check control input voltage at connection (inside transformer box).
- Make sure that the dial on the motor is opened CW.

Figure 1. Remote Mounted Dial Wiring Diagram — 120VAC Single Phase

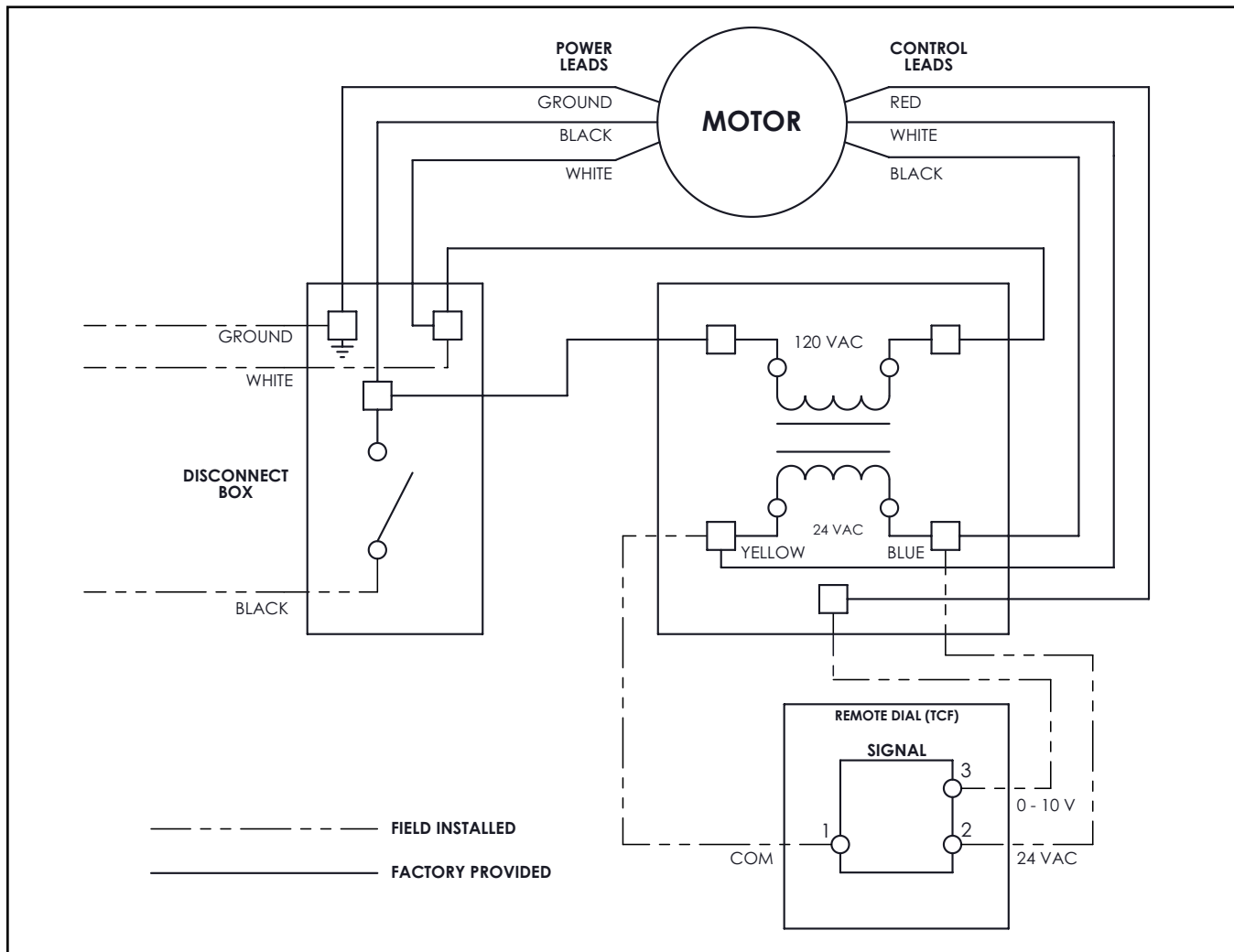
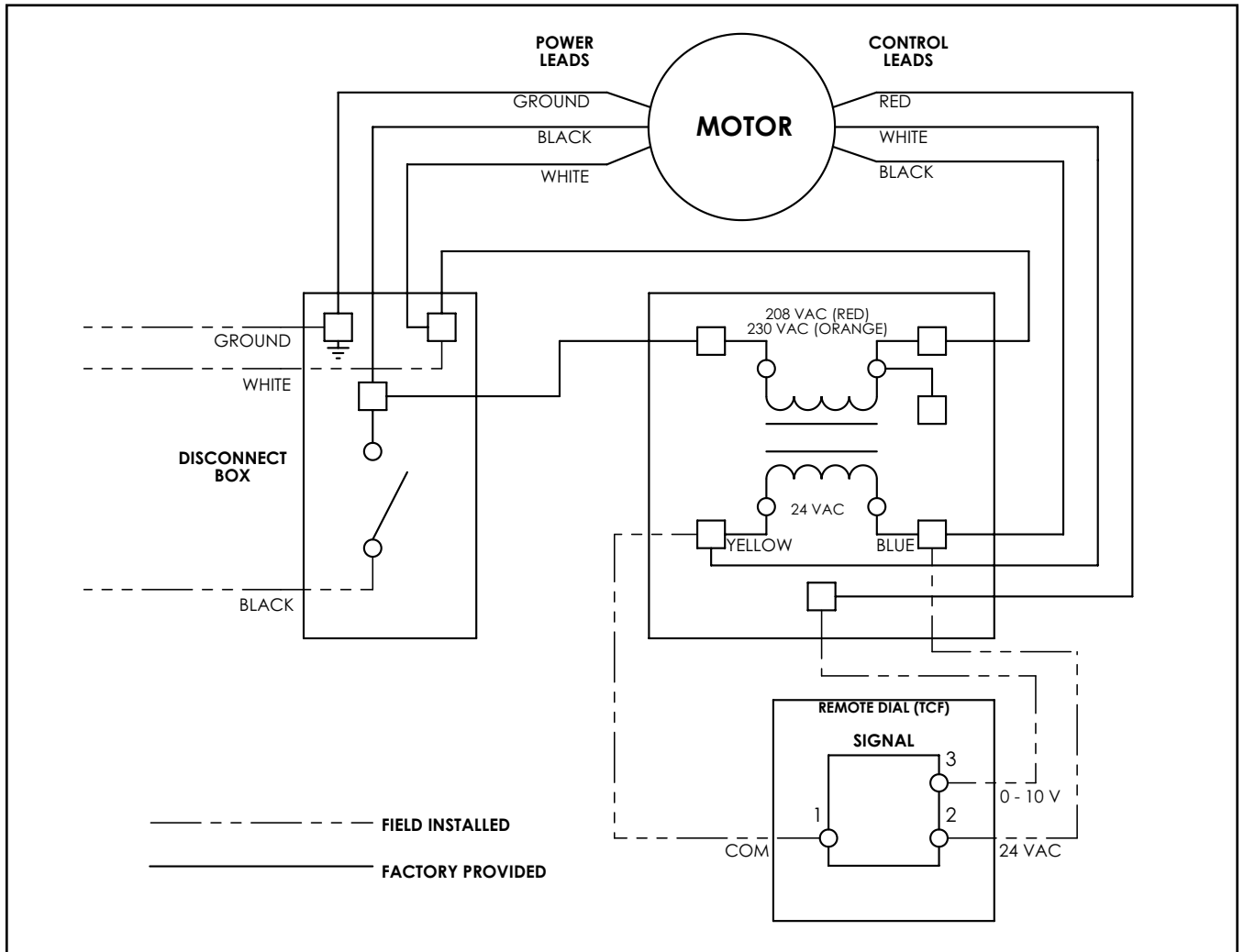

Figure 2. Remote Mounted Dial Wiring Diagram — 230VAC Single Phase



Speed Control Options: ECTEFC Motors

This section covers the motors listed in the following chart:

TCF Part Number	Manufacturer's Part Number	HP	Voltage/Phase
67002205	DV3300A01	1	115/208-230/1
67002107	DV3302A01	2	208-230/1

Installation

1. Connect the motor to AC power and ground the external speed control. Follow Figures 3 and 4 below for appropriate voltage. Use appropriate strain relief (not provided) and branch protection.

⚠ CAUTION

Do not remove conduit box cover for at least five (5) minutes after AC power is disconnected to allow capacitors to discharge. Dangerous voltages are present inside the equipment even when the motor is not rotating. Electrical shock can cause serious or fatal injury.

AC power

Connect it to the motor control as follows:

- a. Connect 115VAC (Black) to L1.
- b. Connect Neutral (White) to N.
- c. Connect Ground to ⊕

Use only Copper Wire for all wiring, minimum 75°C.

⚠ CAUTION

Connection of 115VAC power to "N" will damage the unit.

Figure 3. 115VAC Power Connection to Motor Speed Controller

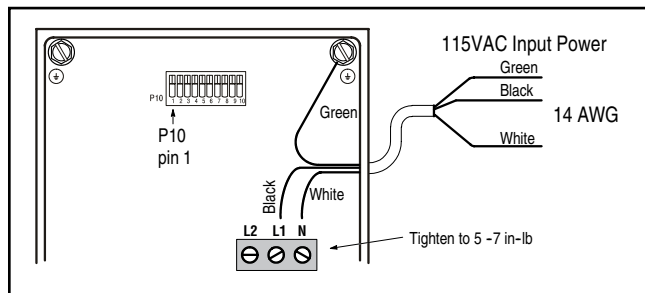

AC power

Connect it to the motor control as follows:

- a. Connect 230V (White) to L1.
- b. Connect 230V (Black) to L2.
- c. Connect Ground to ⊕

Use only Copper Wire for all wiring, minimum 75°C.

⚠ CAUTION

Connection of 230VAC power to "N" will damage the unit.

Figure 4. 230VAC Power Connection to Motor Speed Controller

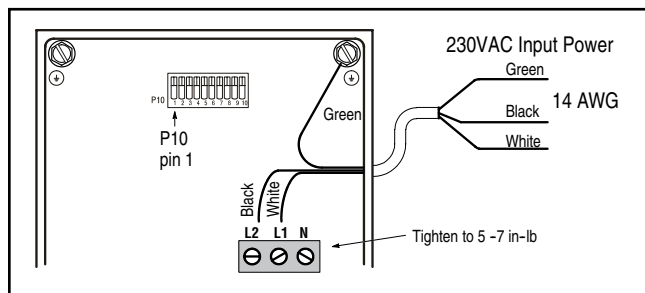

Table 1. Single Phase Power Requirements

Nominal AC Voltage	Minimum AC Volts	Maximum AC Volts	HP	Input A _{RMS}	Output A _{RMS}
115	103	126	1.0	12.0	2.83
			1.0	6.0	2.83
230	200	264	2.0	12.0	5.29

Note: Internally, the Speed Controller provides 240VAC 3 phase at 8kHz switching frequency to the motor.

Table 2. Branch Protection

Motor Assembly	Fuses				Maximum UL Listed Circuit Breaker
	Fast-Acting		Time-Delay		
	Class #	Max Rating	Class	Max Rating	
All (1HP-2HP)	RK1	20A	RK5	20A	20A

- A different fuse Class may be used as an alternative to the Class shown, provided it is of the same or lesser rating and has equivalent (or better) clearing time and peak let-through characteristics (i.e. Class H, K1, J, T, etc.)

2. Connect the motor to the appropriate speed control option. The motor ships from the factory with 1 of 2 methods for speed control depending on what was ordered. The first method is a potentiometer (also known as a remote speed control or motor mounted dial). This is an analog dial which controls the speed of the motor by sending a variable 0-10VDC signal to the motor. CW rotation of the potentiometer increases the speed and CCW rotation decreases the speed (all the way CCW turns the motor off). Note that the motor will run between 2-10V and will shut off from 0-1.9V. See Figure 5 on page 6 for details on wiring a potentiometer if required.

Figure 5. Motor Speed Controlled by a Remote Speed Control Dial (Potentiometer)

Connect the Speed Control Potentiometer to the motor control as follows:

- Connect one end of Potentiometer to P10-1 (12VDC).
- Connect center (wiper) of Potentiometer to P10-2 (Analog Input)
- Connect other end of Potentiometer to P10-3 (DGND)

Use only Copper Wire for all wiring.

The second speed control method is to send the motor a 0-10VDC control signal. From the factory, a 2-wire harness is provided for field connections. Note that the motor does not require a 24V power source to operate in this mode. See Figure 6 below.

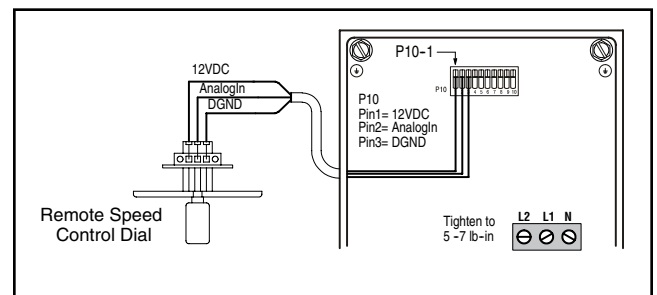

Figure 6. Motor Speed Controlled by 0-10VDC Control Signal

Connect the Control Signal Harness to the motor control as follows:

- Connect a positive voltage source to pin P10-2 (AnalogIn)
- Connect source common to P10-3 (DGND)

Use only Copper Wire for all wiring.

Description	Wire Color
0-10VDC (Analog Input)	Red
Ground (DGND)	White

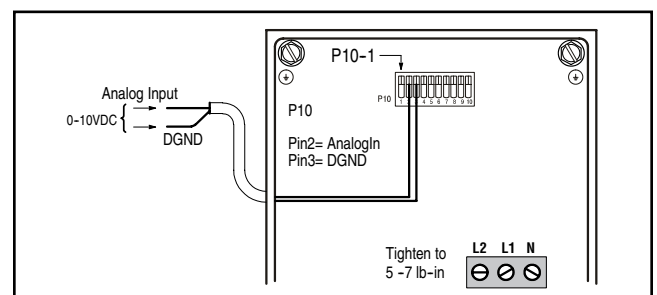

It is the responsibility of the installer/controls engineer to ensure that any field supplied controls are compatible and functional with this motor technology. TCF is not responsible for field supplied or customer designed fan or motor controls.

3. Verify rotation of motor is correct by energizing the motor and checking the rotation matches the fan rotation label. This can also be done before any speed controls are wired in by placing a jumper wire between terminals Pin 1 and Pin 2. This will send 10 volts into the motor and cause it to run at full speed. To change the rotation of the motor, swap the T1 (Black) and T2 (Blue) leads. Note that the motor and fan warranty are void if the motor is rotating in the incorrect direction. Also verify that the motor speed control is functioning properly.

Connections

This motor is designed to be connected to the three-phase supply mains at all times. Motor operation is controlled by an analog DC voltage signal. The motor is shipped with all necessary internal connections made for signal, power, and ground connections. The three-phase AC lines are labeled “L1”, “L2”, and “L3” and the earth ground line is a green and yellow wire. The customer is required to connect the three-phase AC lines and earth ground to their supply.

Figure 7. Connections for signal and power leads

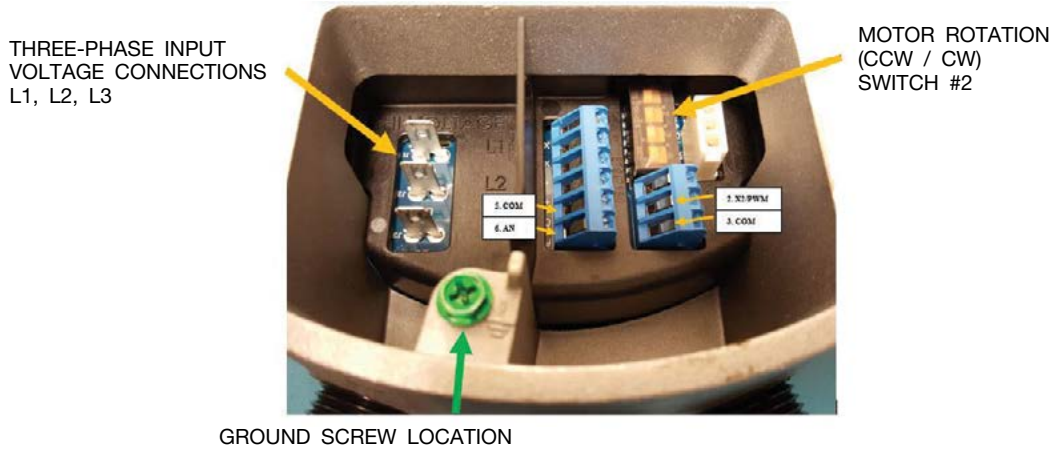

Figure 8. Connection label supplied on cover plate

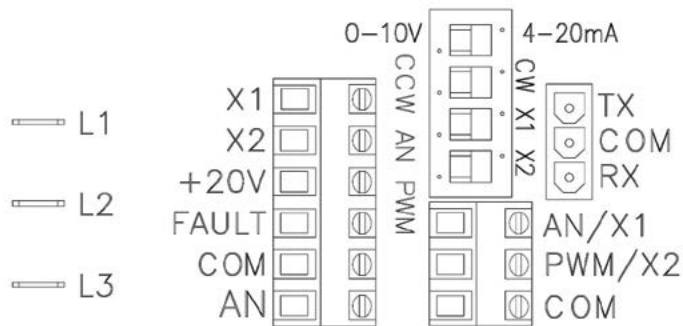

Table 3. Symax motors

TCF Part Number	Manufacturer's Part Number	HP	Voltage/Phase
67003105	E56Y22VBH2048	1	208 - 230/3
67003106	E56Y22VBH2049	1½	208 - 230/3
67003107	E56Y22VTH2046	2	208 - 230/3
67003109	E56Y22VTH2047	3	208 - 230/3
67003405	E56Y42VBH2048	1	460/3
67003406	E56Y42VBH2049	1½	460/3
67003407	E56Y42VTH2046	2	460/3
67003409	E56Y42VTH2047	3	460/3

Operation Method Motor

This engineering sample is setup for constant speed operation. The analog DC control voltage controls the target speed to maintain. Speed maximum setting (10V) has been set for 1750 RPM. Speed minimum setting has been set for 200 RPM with a turn on speed of 250RPM at ~1.6V. The torque to speed relationship is dependent on the load on the motor.

Control Method

0-10Vdc

The default motor control method is 0-10V DC where 0V is off and 10V is full speed. DC signal should be applied per Figure 1. +V DC line attached where shown (AN). DC common line should be attached per Figure 6 where shown (COM).

Maintenance

These motors use brushless technology with sealed bearings so no maintenance is required other than keeping the motors dry and free of dirt, dust and debris.

Troubleshooting

Speed control does not vary the motor speed

- Check voltage to ensure the motor is receiving the correct input voltage.
- Check voltage at the remote dial. 12VAC should be present across the 12V and COM terminals and 0-10VDC should be present between the 0-10V and COM terminals.
- Verify that the potentiometer or 0-10VDC lead is properly wired to the control board according to the diagram.
- Verify that all of the connections inside of the fan and motor are secure.

Motor does not operate

- Check that the motor is wired for the correct supply voltage.
- Verify the Status LED is solid red.
- Verify that the jumper wire is present between terminals 9 and 10 on the low voltage terminal board because this is required for the motor to operate.
- Verify that the yellow wires are present on terminals 5 and 6 on the low voltage terminal board.

Fault indication

A red LED is located either on the control board or on the side of the conduit box to provide diagnostic assistance of motor faults. When a fault occurs, the LED will blink a specific number of times to identify the fault that has occurred. The fault indications are as follows:

No. of Blinks	Indicated Fault
2	Overcurrent
3	Overvoltage
4	Undervoltage
5	Communication Error
6	Sync Loss
7	Spin Fault
8	3Sec/60sec Motor Overload
9	Motor Over-temperature

When a fault occurs, the LED will blink the number of times corresponding to the fault, pause and then repeat blinking. Count the number of blinks multiple times to ensure that the proper fault has been identified. With most of the faults, the motor will restart automatically. If the motor experiences an overload fault over 10 times within an hour, the motor will shut down to protect itself and the power will need to be reset.

Limitation of Warranties and Claims

Seller warrants to the original purchaser that the goods sold hereunder shall be free from defects in workmanship and material under normal use and service (except in those cases where the materials are supplied by the buyer) for a period of one year from the date of original installation or eighteen (18) months from the date of shipment, whichever occurs first. The liability of seller under this warranty is limited to replacing, repairing, or issuing credit (at cost, F.O.B. factory and at seller's discretion) for any part or parts which are returned by buyer during such period provided that:

- a. seller is notified in writing within ten (10) days following discovery of such defects by buyer, or within ten (10) days after such defects should reasonably have been discovered, whichever is less;
- b. the defective unit is returned to seller, transportation charges prepaid by buyer.
- c. payment in full has been received by seller or said products; and
- d. seller's examination of such unit shall disclose to its satisfaction that such defects have not been caused by misuse, neglect, improper installation, repair, alteration, act of God, or accident.

No warranty made hereunder shall extend to any seller product whose serial number is altered, effaced or removed. Seller makes no warranty, express or implied, with respect to motors, switches, controls, or other components of seller's product, where such components are warranted separately by their respective manufacturers. THIS WARRANTY IS EXPRESSLY IN LIEU OF ALL OTHER WARRANTIES, EXPRESS OR IMPLIED, WHETHER STATUTORY OR OTHERWISE, INCLUDING ANY IMPLIED WARRANTY OF MERCHANTABILITY OR FITNESS FOR A PARTICULAR PURPOSE. In no event shall seller be liable to buyer for indirect, incidental collateral, or consequential damages of any kind. (BUYER'S FAILURE TO PAY THE FULL AMOUNT DUE WITHIN SIXTY (60) DAYS OF DATE OF INVOICE SHALL OPERATE TO RELEASE SELLER FROM ANY AND ALL LIABILITY OR OBLIGATION ARISING PURSUANT TO ANY WARRANTY, EXPRESS OR IMPLIED, WHETHER STATUTORY OR OTHERWISE, INCLUDING ANY IMPLIED WARRANTY OR MERCHANTABILITY OR FITNESS FOR A PARTICULAR PURPOSE, MADE IN CONNECTION WITH ANY CONTRACT FORMED HEREUNDER. BUYER AGREES THAT SUCH FAILURE TO PAY SHALL CONSTITUTE A VOLUNTARY WAIVER OF ANY AND ALL SUCH WARRANTIES ARISING PURSUANT TO SUCH CONTACT.)



TWIN CITY FAN & BLOWER | WWW.TCF.COM

5959 Trenton Lane N | Minneapolis, MN 55442 | Phone: 763-551-7600 | Fax: 763-551-7601