



Introduction

The purpose of this manual is to provide instructions that complement good general practices when installing or operating fans manufactured by TC Axial. It is the responsibility of the purchaser to provide qualified personnel experienced in the installation, operation, and maintenance of air moving equipment.

As always, follow good safety practices when installing, maintaining and operating your air moving equipment. A variety of safety devices is available. It is the user's responsibility to determine adequate safety measures and to obtain the required safety equipment.

Shipping and Receiving

All TC Axial products are carefully constructed and inspected before shipment to insure the highest standards of quality and performance.

Compare all components with the bill of lading or packing list to verify that the proper unit was received.

Check each unit for any damage that may have occurred in transit. Any damage should be reported immediately to the carrier and the necessary damage report filed.

Handling

Handling of all air moving equipment should be conducted by trained personnel and should be consistent with safe handling practices. Verify the lift capacity and operating condition of handling equipment. Maintain handling equipment to avoid serious personal injury.

Units shipped completely assembled may be lifted with slings and spreader bars. Use well-padded chains, cables or nylon straps. On most units, lifting lugs are provided for attaching chains. Lift the fan in a fashion that protects the fan and fan coating from damage. Never lift a fan by the inlet or discharge flange, shafting or drives, wheel or impeller, motor or motor base, or in any other manner that may bend or distort parts.

If fan installation is to be delayed, store the unit in a protected area. Protect the fan and motor bearings from moisture and vibration (or shock loading). For extended storage, wrap entire unit in plastic.

Extended storage requires monthly inspections. Check for corrosion or damage to the unit and for debris within the fan. Rotate the fan wheel a few revolutions. Stop the wheel in a position other than the initial position. Grease the bearings every month with a grease compatible with the grease supplied with the bearings.

Foundations and Supporting Structures

Typical mounting arrangements are shown in Figures 4 and 5 on pages 3 and 4. Floor mounted fans should be installed on a flat, level, rigid concrete foundation. They require the mass of the foundation to be at least three times that of the fan assembly. The plan area should be no more than twice that required by the equipment. Foundations with larger areas should have correspondingly larger mass. Anchor bolts should be "L" or "T" shaped with sufficient length for nuts, washers, shims, and threads for draw-down. Each bolt should be placed in a sleeve or pipe with a diameter larger than the bolt to allow for adjustment. When the mounting

surface and the surface of the fan base do not match, shim or make allowance for grouting. Do not distort the fan when tightening the anchor bolts.

Fans mounted to or within a structure should be placed as close as possible to a rigid member such as a wall or column. The structure must be designed for rotating equipment; static design for strength is not sufficient to insure proper operation. Supports for suspended fans must be cross-braced to prevent side sway. Structural resonance should be at least 20% from fan operating speed. Vibration isolators should be used where applicable.

Any ducting should have independent support; do not use the fan to support ducting. Isolating the fan from ductwork with flex connections eliminates transmission of vibration. Fans handling hot gases require expansion joints at both the inlet and discharge to prevent excessive loads caused by thermal growth.

Fan Installation, Factory Assembled Units

Follow proper handling instructions as given earlier.

1. Move the fan to the final mounting position.
2. Remove skid, crates, and packing materials carefully.
3. Place vibration pads or isolation base on mounting bolts. Line up holes in fan base with bolts.
4. Place fan on mounting structure. Carefully level the unit using shims as required at all mounting hole locations. Bolt down the unit.
5. Any grout may now be used. Bolt the fan in position before applying grout. Do not depend upon grout to support rotating equipment.
6. Continue with Operations Checklist.

General Motor Maintenance

The three basic rules of motor maintenance are: keep the motor clean, keep it dry, and keep it properly lubricated.

Blow dust off periodically (with low pressure air) to prevent the motor from overheating.

Some smaller motors are lubricated for life. Motors less than 10 hp running about eight hours a day in a clean environment should be lubricated once every five years; motors 15 to 50 hp, every 3 years; and motors 50 to 150 hp, yearly. For motors in a dusty or dirty environment or running 24 hours a day, divide the service interval by 2. If the environment is very dirty or high temperatures exist, divide the service interval by 4. Lubrication requirements are normally attached to the motor. Do not overlubricate.

Drive Maintenance

V-belt drives need periodic inspection and occasional belt replacement. When inspecting drives, look for dirt buildup, burrs or obstructions that can cause premature belt or drive replacement. If burrs are found, use fine emery cloth or a stone to remove them. Be careful that dust does not enter the bearings. Check sheaves for wear. Excessive slippage of belts on sheaves can cause wear and vibration. Replace worn sheaves with new ones. Carefully align sheaves to avoid premature sheave failure.

Inspect the belts for wear. If fraying or other wear is observed to be mostly on one side of the belts, the drives may be misaligned. Reinstall the drives according to the following instructions:

1. Slip (do not pound) the proper sheave onto its corresponding shaft. **Caution:** *Reversing the sheaves (placing the fan sheave on the motor shaft) can overspeed the wheel and cause structural failure.*
2. Align sheaves with a straightedge extended along the sheaves, just making contact on the outside perimeters of both sheaves. (See Figure 1.)
3. Tighten sheave bolts.
4. Adjust the motor position to obtain slack. Install and tighten belts. Use a matched set of belts. Using a pry will damage belts. Never use belt dressing on any belts.
5. Tighten belts to proper belt tension. Ideal tension is just enough so that the belts do not slip under peak load. Recheck sheave alignment.
6. New belts require a break-in period of operation so recheck the belt tension after a few days of operation.
7. When replacing belts replace the entire set and follow the procedure above.

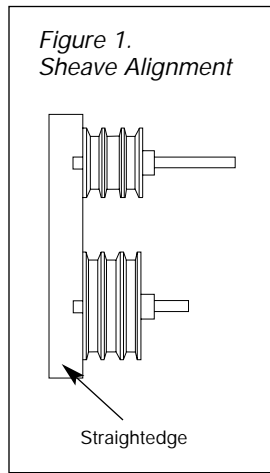

Drive Adjustment

On small fans, the belt tension is adjusted by loosening the four nuts on top of the motor plate and turning the four nuts underneath the motor plate to achieve the proper belt tension. Tighten the top four nuts to hold the motor plate in place. Care should be taken to maintain drive alignment as described above. Large fans use a pivoting motor mounting plate. Adjust the belt tension by loosening the two nuts and bolts on the pivoting side of the motor plate, and the nuts that hold the eyebolts to the motor plate on the other side. Turn the nuts on the eyebolts that are underneath the motor plate to achieve the proper belt tension and then tighten the top nuts and the pivot side nuts and bolts. When tightening the nuts that are on the eyebolts, take care to maintain proper drive alignment.

Positioning the motor plate at too high of an angle may result in the belts rubbing against the belt tube inside the fan. The motor plate pivot bolt must be moved up or down to the next hole to keep the drives centered in the belt tube. The ideal motor plate position is perpendicular to the belt tube centerline.

Bearing Lubrication

Proper lubrication of belt drive bearings helps assure maximum bearing life. All fans are equipped with decals indicating relubrication intervals for normal operating conditions. However, conditions at every installation are different and the frequency of relubrication should be established accordingly. Figure 2 shows the relubrication schedule for ball bearings. Figure 3 shows the relubrication schedule for solid pillow block spherical roller bearings.

Lubrication intervals should be doubled on fans with vertical shafts.

On high moisture applications, the relubrication frequency may need to be doubled or tripled to adequately protect the bearings. Carefully replace the joint sealant under the

bearing access cover whenever the bearings on high moisture fans are serviced.

Observation of the condition of the grease expelled from the bearings at the time of relubrication is the best guide as to whether regreasing intervals and the amount of grease added should be altered.

Figure 2. Ball Bearing Relubrication Schedule

WARNING

1. This equipment must not be operated without proper guarding of all moving parts. While performing maintenance be sure remote power switches are locked off. See AMCA Publication 410 for recommended safety practices.
2. Before starting: Check all setscrews for tightness, and rotate wheel by hand to make sure it has not moved in transit.

Relubrication Schedule (Months)* Ball Bearing Pillow Blocks									
Speed (RPM)	500	1000	1500	2000	2500	3000	3500	4000	4500
Shaft DIA									
1/2" thru 1 1/16"	6	6	5	3	3	2	2	2	1
1 5/16" thru 2 7/16"	6	5	4	2	2	1	1	1	1
2 1/16" thru 2 5/16"	5	4	3	2	1	1	1		
3 7/16" thru 3 5/16"	4	3	2	1	1	1			

*Suggested initial greasing interval: Rotate bearings during relubrication where good safety practice permits until some purging occurs at seals. Adjust lubrication frequency depending on condition of purged grease. Hours of operation, temperature, and surrounding conditions will affect the relubrication frequency required.

1. Lubricate with a high quality NLGI No. 2 or No. 3 multipurpose ball bearing grease having rust inhibitors and antioxidant additives. Some greases having these properties are:
 - Shell - Alvania No. 2 Mobil - Mobilith 22/Mobilith SHC100
 - Gulf - Gulfcrown No. 2 Amoco - Rykon Premium 2
2. Lubricate bearings prior to extended shutdown or storage and rotate shaft monthly to aid corrosion protection.

Figure 3. Solid Pillow Block Spherical Roller Bearing Relubrication Schedule

WARNING

1. This equipment must not be operated without proper guarding of all moving parts. While performing maintenance be sure remote power switches are locked off. See AMCA Publication 410 for recommended safety practices.
2. Before starting: Check all setscrews for tightness, and rotate wheel by hand to make sure it has not moved in transit.

*Suggested initial greasing interval: Rotate bearings during relubrication where good safety practice permits until some purging occurs at seals. Adjust lubrication frequency depending on condition of purged grease. Hours of operation, temperature, and surrounding conditions will affect the relubrication frequency required.

Relubrication Schedule (Months)* Spherical Roller Bearing - Solid Pillow Blocks									
Speed (RPM)	500	1000	1500	2000	2500	3000	3500	4000	4500
Shaft DIA									
1 3/16" thru 1 7/16"	6	4	4	2	1	1	1	1	1/2
1 11/16" thru 2 3/16"	4	2	1 1/2	1	1/2	1/2	1/2	1/2	1/2
2 7/16" thru 3 7/16"	3	1 1/2	1	1/2	1/2	1/4	1/4		
3 5/16" thru 4 5/16"	2 1/2	1	1/2	1/4					

1. Lubricate with a multipurpose roller bearing NLGI No. 2 having rust inhibitors and antioxidant additives, and a minimum oil viscosity of 500 SSU at 100°F. Some greases having these properties are:
 - Shell - Alvania No. 2 Texaco - Premium RB2
 - Mobil - Mobilith SHC100 Amoco - Rykon Premium 2
2. Lubricate bearings prior to extended shutdown or storage and rotate shaft monthly to aid corrosion protection.

Greases are made with different bases. There are synthetic base greases, lithium base, sodium base, etc. Avoid mixing greases with different bases. They could be incompatible and result in rapid deterioration or breakdown of the grease.

All bearings are filled with a lithium based grease before leaving the factory. When the fans are started, the bearings may discharge excess grease through the seals for a short period of time. Do not replace the initial discharge because leakage will cease when the excess grease has worked out. Bearings have a tendency to run hotter during this period and should not be a cause for alarm unless it lasts over 48 hours or gets very hot. When relubricating, use a sufficient amount of grease to purge the seals. Rotate bearings during relubrication where good safety practice permits.

Propeller and Shaft Maintenance

The buildup of material on axial flow propellers can adversely affect fan performance. While fans that handle clean, fresh air seldom need cleaning, occasionally check fans used for industrial purposes for material buildup on the propeller. This material can come off in large chunks, throwing the propeller out of balance. Clean the propeller and, on vaneaxial fans, the turning vanes; when appropriate, apply new coatings.

If the propeller is removed for any reason, make sure that it is securely attached to the shaft before restarting the fan. If the propeller is attached to the shaft by means of a Trantorque® bushing, use the tightening torque values shown in Table 1.

Table 1.

TRANTORQUE® SIZE	SHAFT DIA.	SOCKET SIZE	TORQUE (IN. LBS.)	TORQUE (FT. LBS.)
7/8	7/8	1 1/2	850	71
1 1/8	1 1/8	1 3/4	1550	130
1 3/8	1 3/8	2	1700	141
1 5/8	1 5/8	2 1/4	2800	233
1 7/8	1 7/8	2 1/2	3900	325
2 1/8	2 1/8	2 3/4	5300	440
2 3/8	2 3/8	3	5600	470
2 7/8	2 7/8	3 1/2	6600	550

Note: These torque values are to be obtained with a calibrated torque wrench. DO NOT apply any lubricant to any part of the Trantorque® hub. DO NOT use an anaerobic thread adhesive such as Loctite® on the threads.

Structural Maintenance

All structural components or devices used to support or attach the fan to a structure should be checked at regular intervals. Vibration isolators, bolts, foundations, etc., are subject to failure from corrosion, erosion, and other causes. Improper mounting can lead to poor operation characteristics or fan fatigue and failure.

Check metallic components for corrosion, cracks, or other signs of stress. Concrete should be checked to insure the structural integrity of the foundation.

Operation Checklist

Verify that proper safety precautions have been followed:

- Electrical power must be locked off.

Check fan mechanism components:

- Nuts, bolts and setscrews are tight.
- Mounting connections are properly made and tightened.
- Bearings are properly lubricated.
- Propeller, drive and fan surfaces are clean and free of debris.
- Rotating assembly turns freely and does not rub.
- Sheaves are on the correct shafts, properly aligned and properly tensioned.

Check fan electrical components:

- Motor is wired for proper supply voltage.
- Motor size is sufficient to power the rotating assembly.
- Motor is properly grounded.
- All leads are properly insulated.

Trial "bump":

- Turn on power just long enough to start assembly rotating.
- Check rotation for agreement with rotation arrow.
- Listen for any unusual noise.

Run unit up to speed:

- Bearing temperatures <180°F are acceptable after one to two hours of operation.

After one week of operation:

- Check all nuts, bolts and setscrews and tighten if necessary.
- Readjust drive tension if necessary.

Figure 4. Horizontal Mounting Arrangements

Horizontal With Suspension Clips

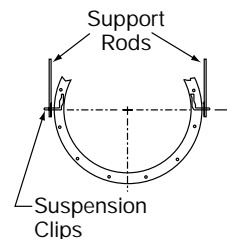

Horizontal With Support Legs

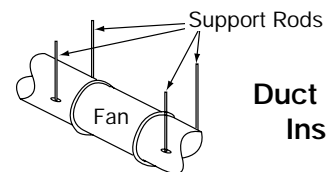
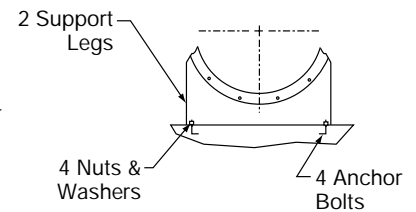

Duct Supported Installation

Figure 5. Vertical Mounting Arrangements

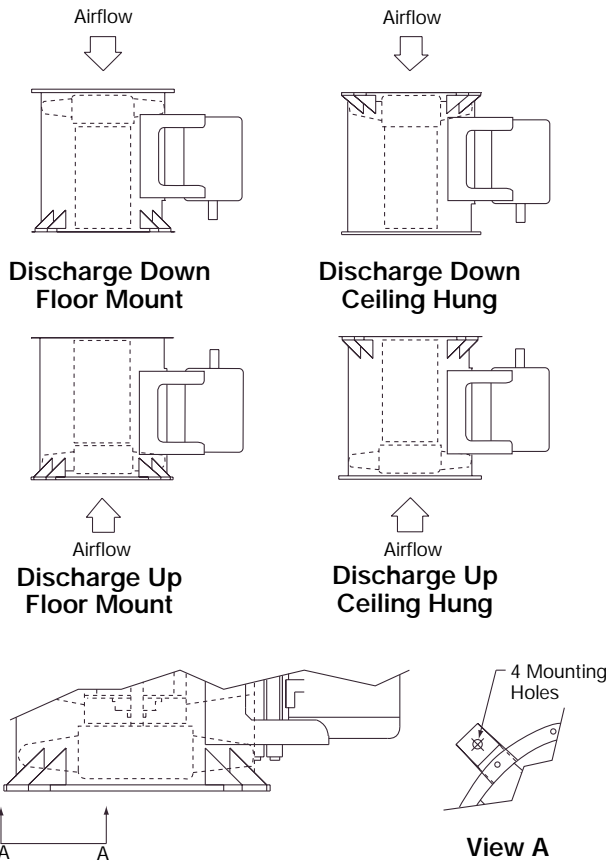

Blade Adjustment on Adjustable Pitch Vaneaxial Type TCVX

Blade Angle Adjustment

The blades are set at the factory to the blade angle that gives the performance specified on the order. This angle should be checked prior to start-up. The patented wheel construction uses friction and centrifugal force to hold the blades in place. No disassembly of the wheel is required to change the blade angles. If it is necessary to change the blade angle, the following procedure should be used:

1. Work safely. Make sure that proper safety precautions have been followed. Electrical power must be locked off.
2. The adjustment can be made through the inlet on open inlet fans. On fans with ducted inlets, open the wheel area access door.

3. Place adjustment tool around end of blade (see Figure 6, below). If necessary, apply "cheater bar" around the 1 1/4" diameter end for additional leverage.

The blades can be turned by hand on open inlet fans. If additional leverage is needed, place a wrench on the leading edge of the blade near the hub. Take care not to mar the surface of the blade.

4. **Prior to adjusting the blade angle, check the performance data to insure that the motor will not overload.**
5. Turn blade to desired angle. See Figure 6. There is an indicator mark on the hub. Align the Vernier index line on the blade with the indicator mark on the hub. The Vernier has the characters 3, 4, and 5 with gradation lines in between. (**Note:** Character 3 is 30°, 4 is 40°, 5 is 50°.) Each gradation is 2.5°. The blade is adjustable between 25° and 50°.
6. Friction and centrifugal force will hold the blade at the set angle. No additional adjustment is necessary.
7. **Adjust all blades to the same angle.**
8. Close the wheel area access door before operating the fan.

Figure 6.

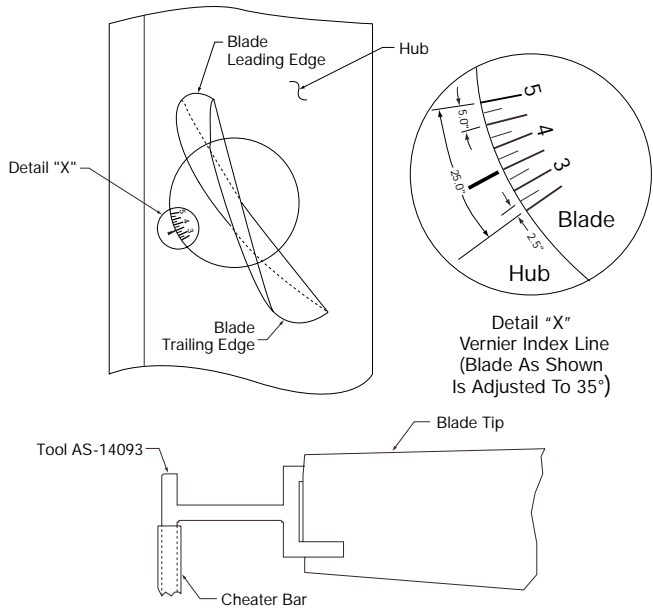

TCAxial

A Twin City Fan Company

5959 Trenton Lane · Minneapolis, MN 55442-3238
Phone (763) 551-7600 · Fax (763) 551-7601 · www.tcaxial.com

