

Piezometer Ring (Airflow Measuring System)

Twin City Fan is pleased to introduce The Piezometer Ring Airflow Measuring System, now available as an accessory for our housed and plenum fans. The system consists of a Piezometer ring mounted at the throat and a static pressure tap mounted on the face of the inlet cone. A differential pressure transducer and digital display can also be provided. Based on Twin City Fan laboratory tests, the system was determined to be accurate within +/-5%.

How it Works

The System is based on the principle of a flow nozzle. The inlet cone of the fan is used as the flow nozzle, and the flow can be calculated by measuring the static pressure drop through the inlet cone.

The pressure drop is measured from the tap located on the face of the inlet cone to the piezometer ring in the throat. The inlet tap is connected to the high-pressure side of the transducer and the piezometer ring is connected to the low-pressure side (see diagram at right).

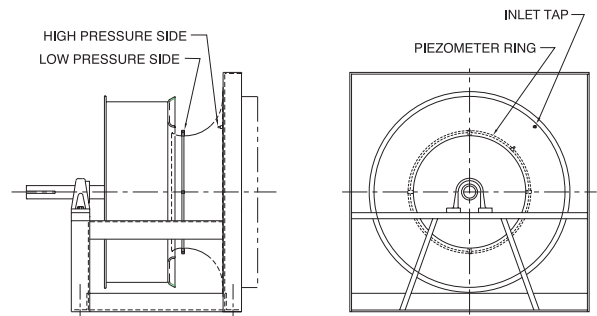
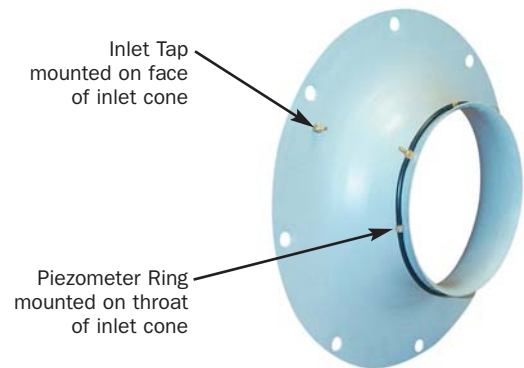

Demonstration

Shown below is a Twin City Fan model 165 BCV fitted with a Piezometer Ring Airflow Measuring System, operating at 1100 RPM. With an unobstructed inlet, the digital display indicates the fan is producing 1713 CFM, which closely matches rated performance (see photo A). After placing an obstruction in the inlet, the airflow is reduced to 1597 CFM (see photo B).



A. Fan operating with unobstructed inlet produces 1713 CFM



B. Fan operating with obstructed inlet produces 1597 CFM

